

NOV 5 1995

STORMWATER BEST MANAGEMENT PRACTICES



**N.C. Department of Environment, Health and Natural Resources
Division of Environmental Management
Water Quality Section**

November 1995



	Page Number
General Introduction	1
Chapter 1. Wet Detention Ponds	2
I. Introduction	2
II. Design Requirements	3
III. Example Basin Design	5
IV. Operation and Maintenance	7
V. Inspections	8
VI. Peak Flow Reduction	11
VII. Certification/Approval	11
VIII. Definitions	11
IX. References	13
Chapter 2. Stormwater Wetlands	16
I. Introduction	16
II. General Characteristics	16
III. Advantages	19
IV. Disadvantages	20
V. Costs	20
VI. Design Requirements	20
VII. Maintenance	24
VIII. Peak Flow Reduction	24
VIII. References	24
Chapter 3. Sand Filters	
I Introduction	26
II Design Requirements	27
III Maintenance Requirements	31
Chapter 4. Bioretention Areas	
I. Introduction	32
II. Bioretention Concept	33
A. Functions of the Bioretention Area Components	33
B. Minimum Design Size Requirements	36
C. Bioretention Area Types	36
III. Grading Plan	
A. Locating the Bioretention Area	42
1. Stormwater Management Concept Plan	42
2. Location Guidelines	42
B. Sizing Guidelines	42
C. Drainage Considerations	45
D. Grading Plan Guidelines	45
IV. Planting Plan	
A. Planting Plan Concept	47
B. Plant Species Selection	47
C. Site and Ecological Considerations	48
D. Number of Species	48

E.	Number and Size of Plants	49
F.	Plant Material Layout	49
V.	Soil, Mulch, and Plant Material Guideline	
A.	Planting Soil Guidelines	51
1.	Soft Texture and Structure	51
2.	Soil Acidity	51
3.	Soil Testing	51
4.	Soil Placement	53
B.	Mulch Layer Guidelines	53
C.	Plant Material Guidelines	53
1.	Plant Material Source	53
2.	Installation	53
3.	Warranties	45
D.	Plant Growth and Soil Fertility	55
1.	Plant Growth	55
2.	Soil Fertility	55
VI.	Maintenance Guidelines	56
A.	Planting Soil	56
B.	Mulch	56
C.	Plant Materials	56
VII.	Peak Runoff Control and Pollutant Reduction	59
VIII.	Water Balance for Bioretention Areas	
A.	Water Balance Methodology	60
B.	Parameters	60
1.	Precipitation/Runoff	60
2.	Evapotranspiration	61
3.	Infiltration	61
C.	Results	62
IX.	Bioretention Area: Soil Specifications	
A.	Planting Soil	63
B.	Mulch Layer Specifications	63
C.	Sand Specifications	63
D.	Compaction	63
X.	Bioretention Area: Plant Specifications	64
XI.	References	66
Chapter 5. Grassed Swales		
I.	Introduction	68
II.	General Characteristics	68
III.	Advantages	68
IV.	Disadvantages	70
V.	Costs	70
VI.	Design Requirements	70
VII.	Maintenance	70
VIII.	References	71
Chapter 6. Extended Dry Detention Basins		
I.	Introduction	72
II.	Advantages	72

III.	Disadvantages	72
IV.	Costs	72
V.	Design Requirements	74
VI.	Additional Design Considerations	75
VII.	Maintenance	75
VIII.	Peak Flow Reduction	75
IX.	References	76

Chapter 7. Filter Strips

I.	Introduction	77
II.	Advantages	79
III.	Disadvantages	79
IV.	Costs	79
V.	Physical Requirements	79
VI.	Design Requirements	79
VII.	Vegetation	80
VIII.	Maintenance	80
IX.	Peak Flow Reduction	80
X.	References	81

Chapter 8. Infiltration Devices

I.	Introduction	82
II.	Advantages	82
III.	Disadvantages	84
IV.	Costs	84
V.	Design Requirements	84
VI.	Peak Flow Reduction	85
VII.	Maintenance	85
VIII.	References	85

Stormwater Best Management Practices in North Carolina

Introduction

Management of nonpoint source pollution is a stated goal of the 1987 Water Quality Act. An important source of these pollutants is stormwater runoff from urban and developing areas. This runoff has the potential to degrade water quality in all types of waters, including, among others, those classified as water supply watersheds, shellfish areas and nutrient sensitive waters. The management of stormwater runoff through nonstructural controls (e.g. low density developments) is the preferred method of reducing pollution from urban areas. In cases where low density is not feasible, engineered stormwater controls are viable solutions to reducing pollution. However, proper design of these engineered solutions is essential for adequate pollutant removal. In turn, dissemination of technical information to both engineers and local officials on the design and maintenance of engineered solutions is equally important. Design and review of stormwater BMPs as an engineered solution for stormwater management are the subject of this Division of Environmental Management (DEM) Technical Paper.

DEM's approach to water quality management of stormwater in surface drinking water supply watersheds, the twenty coastal counties and areas near High Quality Waters and Outstanding Resource Waters is based first on minimizing impervious surfaces and, secondly, on treating stormwater runoff from these surfaces. The rules contained within 15A NCAC 2H .1000 for wet detention basins provide information on the appropriate volume of runoff to be controlled and the corresponding basin size and configuration. North Carolina's Stormwater Management rules also allow for the construction of alternative BMPs that meet the pollutant removal design standard of 85% removal of total suspended solids (TSS). This document is meant to supplement the rules in the North Carolina Administrative Code by explaining the stormwater BMPs that will be allowed, their design criteria, and their assumed TSS removal. These guidelines are not meant to replace these rules. The stormwater BMPs that will be reviewed and their assumed TSS removal efficiencies, if designed according to the following specifications, are:

Wet Detention Ponds	85%
Extended Detention Wetlands	85%
Pocket Wetlands	35%
Sand Filters	85%
Bioretention Area	85%
Grassed Swales	35%
Extended Dry Detention	50%
Filter Strips	35%
Infiltration Devices	85%

The devices can be used alone or in combination to achieve the required pollutant removal of 85% TSS. As experience grows in the use and effectiveness of the devices, other BMPs or other specifications may be allowed. DEM will continue to review and modify both the design and the removal efficiencies and will modify them as needed.

Chapter 1 Wet Detention Ponds

I. Introduction

Wet detention basins, designed to provide water quality benefits to downstream waters, are ponds that are sized and configured to provide significant removal of pollutants from the incoming stormwater runoff. They maintain a permanent pool of water that is designed for a target TSS removal rate according to the size and imperviousness of the contributing watershed. Above this permanent pool of water, they are also designed to hold the runoff that results from a 1 inch rain and release this over a period of two to five days. These two basic requirements result in a pond where a majority of the suspended sediment and pollutants attached to the sediment are allowed to settle out of the water. In addition, water is released at a rate such that downstream erosion is lessened for smaller storms. Benefits of wet detention ponds over other stormwater devices are many. Dry detention basins, for example, are less efficient in removing suspended solids and other pollutants (US EPA, 1983; Metropolitan Washington COG, 1983) and hold little aesthetic value (Maryland DNR, 1986). Wet detention basins are also appropriate in areas where infiltration is impractical due to low infiltration rates of the underlying soils. In addition to water quality benefits, wet detention ponds can reduce the peak runoff rate from a developed site and control downstream erosion.

The design of wet detention basins is based on controlling the design runoff volume from the long-term average storm in order to settle out suspended solids and pollutants (such as heavy metals and nutrients). Biological treatment also occurs when aquatic vegetation uses the nutrients found in the water and sediment. DEM uses Driscoll's model (US EPA, 1986) to determine the appropriate size of the permanent pool. This model uses as input a long-term average storm statistically calculated from the historical rainfall record. By using this storm and the appropriate watershed characteristics (e.g., impervious cover and drainage area size), a permanent water quality pool is sized to detain the storm long enough to attain the target TSS. The model incorporates settling that occurs during the storm (dynamic) and between storms (quiescent) to determine the long-term removal efficiency. The movement of the storm runoff through the basin is assumed to occur as plug flow.

In addition to the permanent water quality pool, the basin must also have a temporary water quality pool for extended detention: designed to control runoff from a 1" rainfall. This temporary water quality storage is located above the permanent pool and is necessary for a number of reasons. First being for periods when runoff entering the basin is significantly warmer than the permanent water quality pool. During these periods, plug flow will occur to a lesser extent, and the temporary water quality volume will allow some of the suspended solids to fall out of suspension before being released. The detrimental effects of this will be decreased because the runoff from the 1 inch storm is slowly released over a period of two to five days. Secondly, the slow release of this small storm runoff volume also helps to reduce downstream erosion.

Once the minimum surface area and temporary storage volume of the basin needed to achieve the stated water quality goals is determined, the principal outlet and emergency spillway should be sized for flood and downstream erosion control. The storage allocated to flood control is located on top of both water quality pools, while the storage for downstream erosion control includes the same storage as the temporary water quality pool. In some instances the temporary water quality pool may also serve as sufficient volume for downstream erosion control.

Each locality should decide whether a policy based solely on flood control (i.e., peak flow reduction) or on erosion control (i.e., bed-material load reduction or velocity control, both of which may also control flooding) is appropriate. An example of a flood control goal might be to reduce the 10-yr. post-development peak discharge to the 10-yr. pre-development peak discharge and safely pass the 100-yr. storm. However research has shown that detention practices which only control the after-development peak discharge of large storms are not effective in reducing downstream erosion. The peak flow reduction does not control bed-material loadings or reduce the duration during which the discharge velocity exceeds the critical velocity of the receiving channel (McCuen and Moglen, 1987; Schueler, 1987).

Smaller more frequent storms (those that produce a bankfull flood) are responsible for the majority of streambank erosion (McCuen, 1987; Andersen, 1970; Leopold et al., 1964). In a natural watershed this bankfull flood is caused by a storm which occurs on average every 1.5 to 2 years. However, as the watershed develops and stormwater volumes and peaks increase, bankfull floods occur more frequently and channel erosion is more probable. Therefore, designs based on detaining runoff from a small storm, such as a 1-inch storm, for 48-120 hours should reduce the probability of downstream erosion (Schueler, 1987).

A stormwater routing technique should be executed to assure that each outlet (principal and emergency) performs satisfactorily for its design storm. The wetted perimeter of the basin should be planted with aquatic vegetation (Maryland DNR, 1987; Schueler, 1987; Florida DEP, 1986). This vegetation not only enhances pollutant removal but provides wildlife and waterfowl habitat, and protects the shoreline from erosion.

In addition to proper design, the basin must be routinely maintained to satisfy long-term water quality and flood control goals. The basins may be maintained either by private owner/homeowners associations or by a local government or municipality. Like gas, electricity, and sanitary sewers, stormwater management may be designated as a public "utility." Under this approach, property owners within a jurisdiction are assessed a monthly user-fee which covers capital and operation and maintenance costs for the stormwater management program (Hartigan, 1986 and Charlotte Mecklenburg Stormwater Utilities, 1993). Regardless of the approach, a key to any maintenance program is the allocation of adequate funding and the designation of the responsible party.

The following material consists of an outline of guidance for designing or reviewing a wet detention basin (with references) and an outline of specific wet pond requirements. Figure 1, following the references shows a cross-section of a typical wet detention pond.

II. Design Requirements

Design For Water Quality Control

1. **Permanent Water Quality Pool**
 - a. The surface area required can be determined using the permanent pool surface area / drainage area (SA/DA) ratios for given levels of impervious cover and basin depths as outlined in Table I.1 (15A NCAC 2H .1000).
 - b. Average permanent water quality pool depths should be between 3 to 6 feet. Required minimum of 3 feet.
 - c. Impervious levels used for sizing should be those that are expected in the final buildout of the development, and any offsite runoff that drains to the pond.

- d. Enough volume should be included in the permanent pool to store the sediment that will accumulate between cleanout periods.
 - e. A forebay (which may be established by a weir) must be included to encourage early settling. This allows drainage of only a portion of the basin in order to excavate accumulated sediment. The forebay volume should equal about 20% of the basin volume.
2. Temporary Water Quality Pool
- a. The temporary water quality pool is sized to detain the runoff volume from the first inch of rain. This requirement refers to volume and not a particular design storm.
 - b. The temporary water quality pool for extended detention must be located above the permanent water quality pool.
 - c. The outlet device for this temporary water quality pool should be sized to release the runoff volume associated with the first 1-inch of rainfall over a drawdown period of 48 to 120 hours (2 to 5 days).
3. General
- a. Basin shape should minimize dead storage areas and short circuiting. Length to width ratios should be 3:1 or greater. (Barfield, et al., 1981, pp. 426-429; Florida DEP, 1982, pg. 6-289).
 - b. If the basin is used as a sediment trap during construction, all sediment deposited during construction must be removed before normal operation begins.
 - c. Aquatic vegetation should be included for a wetland type detention basin (Maryland DNR, March 1987; Schueler, 1987, Chapter 4 and 9). A minimum ten foot wide shallow sloped shelf is needed for the edge of the basin for safety and to provide appropriate conditions for aquatic vegetation (Schueler, 1987). This shelf should be sloped 6:1 or flatter and extend to a depth of 2 feet below the surface of the permanent pool (Shaver and Maxted, DNREC, 1994). A list of suitable wetland species and propagation techniques are provided in Schueler (1987) and Maryland DNR (1987), and can be found
 - d. An emergency drain (with a pipe sized to drain the pond in less than 24 hours) should be installed in all ponds to allow access for riser repairs and sediment removal (Schueler, 1987).

An Example of the basics of design for water quality follows.

Surface Area to Drainage Area Ratio (SA/DA) For Permanent Pool Sizing

For 85% Pollutant Removal Efficiency

Table I.1

Impervious %	Permanent Pool Depth (feet)						
	3.0	4.0	5.0	6.0	7.0	8.0	9.0
10	0.59	0.49	0.43	0.35	0.31	0.29	0.26
20	0.97	0.79	0.70	0.59	0.51	0.46	0.44
30	1.34	1.08	0.97	0.85	0.70	0.64	0.62
40	1.73	1.43	1.25	1.03	0.90	0.82	0.77
50	2.00	1.73	1.50	1.33	1.09	1.00	0.92
60	2.39	2.03	1.66	1.51	1.29	1.17	1.10
70	2.75	2.27	1.96	1.79	1.48	1.35	1.29

Numbers given in the body of the table are given in percentages

*** Please note that SA/DA ratio numbers in the table above do not apply to ponds constructed in the twenty coastal counties due to differences in soils, rainfall etc. Please contact the appropriate DEM Regional Office for information on pond designs for these areas.*

III. Example Basin Design

Using the Table I.1 How to find the Surface Area of the Permanent Pool

The numbers in the Table I.1 represent surface area (SA) to drainage area (DA) percentages. SA= the wet detention pond permanent pool surface area required to provide an expected 85% Total Suspended Solids removal. The chart is based on the amount of impervious cover as a percentage of the area draining to the pond and the depth of the permanent pool. Impervious percentages are in the left hand column of the chart and depths are given across the table from 3 feet to 9 feet in one foot increments. If needed, one can interpolate to find the SA/DA ratio that is needed in a particular case.

To determine the required permanent pool size, use the following steps:

1. Calculate the percent impervious cover of the site draining to the pond.
[amount of impervious area / total site area]
2. Determine the average permanent pool depth (or select a depth for comparison purposes).
3. Go to Table I.1 and find the number corresponding to the impervious percentage found above and the depth assumed. This number, taken from the body of the table, represents the permanent pool surface area as a percentage of the drainage area.

4. To determine the required surface area of the permanent pool, take the number from the table, divide by 100 and multiply this number by the contributing drainage area.

Example: assume a 10 acre site with 3 acres of impervious cover.

1. % impervious = $3/10 = 0.30$ or 30%
2. Assume an average permanent pool depth of 4 feet
3. From the chart, with 30% impervious and a 4 foot depth, the SA/DA ratio is given as 1.08%
4. The required surface area would then be;
 $(1.08 / 100) * 10 \text{ acres} = 0.108 \text{ acres}$ or 4,705 square feet

How to find the volume to be controlled from the 1" storm

5. The design runoff volume (the temporary water quality pool) to be controlled must be held in the pond above this pool permanent pool level. An example of finding this volume is shown below.

Example: Again, on the same 10 acre, 30% impervious site.

Using the runoff volume calculations in the "Simple Method" as described by Schueler (1987):

$$Rv = 0.05 + 0.009(I)$$

Rv = runoff coefficient = storm runoff (inches) / storm rainfall (inches)

I = Percent Impervious = Drainage area (acres) / Impervious portion of the drainage area (acres)

In this example:

$$Rv = 0.05 + 0.009 (30)$$

$$Rv = 0.32 \text{ (in./in.)}$$

For the volume that must be controlled:

$$\text{Volume} = (\text{Design rainfall}) (Rv)(\text{Drainage Area})$$

$$\text{Volume} = 1" \text{ rainfall} * 0.32 \text{ (inches /)} * 1/12 \text{ (feet / inches)} * 10 \text{ acres}$$

$$\text{Volume} = 0.267 \text{ acre feet or } 11,616 \text{ ft}^3$$

This volume must be drawn down over a period of two to five days.

NOTE: Other methods may be used to determine the volume of runoff from the 1" storm, but care must be taken because all methods have their limitations and applications. The method shown is used because it offers a conservative estimate of runoff volume for a broad variety of land uses and impervious cover percentages.

IV. Operation And Maintenance

1. Routine maintenance is vital to the proper operation of the wet detention basin (Schueler, 1987, pp. 4.13-4.17; Maryland DNR, 1986). No two ponds are the same, but every pond will require maintenance at some point, and their maintenance needs will vary with the size, type of watershed, location, etc.
2. Adequate funding is one of the most important factors in a successful operation and maintenance program (Maryland DNR, 1986).
3. Designation of a responsible party(ies) is important to assure proper inspection and maintenance.
4. Estimated annual operation and maintenance (O&M) costs for wet detention basins of 5% of construction costs were found in a survey conducted by the State of Maryland on their wet detention basins (Maryland DNR, 1986, pg. 37). In addition the NURP study in Washington, D.C., estimated O&M costs to be 5% of construction costs (Metropolitan Washington COG, 1983, Chapter 3).
5. A study of Maryland basins found that, in general, people had more favorable impressions of wet detention basins, were less likely to throw litter in them, and were more likely to clean and perform routine maintenance on these basins when they were provided a prominent position in the development (Maryland DNR, 1986).
6. A permanent easement must be provided to assure easy access for maintenance. Care should be taken to secure all appropriate legal agreements for the easement.
7. A benchmark for sediment removal should be established to assure adequate storage for water quality and flood control functions.
8. The maintenance needs of any particular wet pond are highly dependent on the condition of the watershed that contributes runoff to the pond. Maintenance should always include minimizing erosion problems and pollutant export to the pond from the contributing watershed.
9. Again, one must remember that while general maintenance tasks are identified here, actual needs will vary from site to site. In general, plans must indicate what operation and maintenance actions are needed, what criteria will be used to determine when these actions are necessary, and who is responsible for these actions. Examples of items that should be included on an Operation and Maintenance plan include, but are not limited to the following:
 - a. Debris and litter control checks for inlet, outlet and orifice obstruction after every storm producing runoff.
 - b. Provisions for routine vegetation management/mowing and a schedule for these activities.
 - c. Checks every 6 months, or more frequently, for:
 - 1) sediment buildup and the need for removal,
 - 2) erosion along the bank and the need for reseeding or stabilization and, if reseeding is necessary, a reseeding schedule,
 - 3) erosion at the inlet and outlet and methods of stabilization,
 - 4) seepage through the dam, and
 - 5) operation of any valves or mechanical components.
 - d. Agreement signed and notarized by the responsible party to perform the tasks specified in the plan, including inspections, operation, and any needed maintenance activities.

V. Inspections

1. North Carolina's stormwater rules require annual inspections by the regulating agency of wet detention ponds as a minimum. More frequent inspections by the land owner, or pond operator are strongly encouraged to ensure the proper operation of a wet detention pond. Local governments can require more frequent inspections, and all local codes should be consulted.
2. The Division of Environmental Management and several local governments have developed inspection sheets that serve as checklists for inspectors. At a minimum, an inspection should include review of the following:
 - a. obstructions of the inlet and outlet devices by trash and debris,
 - b. excessive erosion or sedimentation in or around the basin,
 - c. cracking or settling of the dam,
 - d. deterioration of inlet or outlet pipes,
 - e. condition of the emergency spillway,
 - f. stability of side-slopes,
 - g. up and downstream channel conditions, and
 - h. woody vegetation in or on the dam.
3. An example inspection sheet follows:

POND MAINTENANCE REQUIREMENTS

Project Name: _____ Project Number: _____

Responsible Party: _____ Phone Number: _____

Address: _____

- I. Inspect monthly, or after every runoff-producing rainfall event, whichever comes first
 - A. Remove debris from the trash rack.
 - B. Check and clear the orifice of any obstructions. If a pump is used as the drawdown mechanism, check for pump operation.
 - C. Check the pond side slopes; remove trash, repair eroded areas before the next rainfall event.
 - D. If the pond is operated with a vegetated filter, check the filter for sediment accumulation, erosion and proper operation of the flow spreader mechanism. Repair as necessary.
- II. Quarterly
 - A. Inspect the collection system (i.e., catch basins, piping, grassed swales) for proper functioning. Clear accumulated trash from basin grates and basin bottoms, and check piping for obstructions.
 - B. Check pond inlet pipes for undercutting, replace riprap, and repair broken pipes.
 - C. Reseed grassed swales, including the vegetated filter if applicable, twice a year as necessary. Repair eroded areas immediately.
- III. Every 6 months
 - A. Remove accumulated sediment from the bottom of the outlet structure.
 - B. Check the pond depth at various points in the pond. If depth is reduced to 75% of original design depth, sediment will be removed to at least original design depth.

POND MAINTENANCE REQUIREMENTS CONTINUED

PAGE 2

IV. General

- A. Mow the side slopes, not including normally submerged vegetated shelf, according to the season. Maximum grass height will be 6".
- B. Cattails, and other indigenous wetland plants, are encouraged along the pond perimeter; however, they must be removed when they cover the entire surface area of the pond.
- C. The orifice is designed to draw down the pond in 2-5 days. If drawdown is not accomplished in that time, the system may be clogged. The source of the clogging must be found and eliminated.
- D. All components of the detention pond system must be kept in good working order.

V. Special Requirements

I, _____, hereby acknowledge that I am the financially responsible party for maintenance of this detention pond. I will perform the maintenance as outlined above, as part of the Certification of Compliance with Stormwater Regulations received for this project.

Signature: _____ Date: _____

I, _____, a Notary Public for the State of _____, County of _____, do hereby certify that _____ personally appeared before me this _____ day of _____, 19____, and acknowledge the due execution of the foregoing instrument. Witness my hand and official seal,

SEAL

My commission expires _____

VI. Peak Flow Reduction

The designer should consult with the appropriate local government for specific design or performance requirements. In general, any flood control or peak flow volumes must be calculated using the elevation of the permanent pool as a base. This will include the temporary water quality pool which provides attenuation of the one inch storm.

VII. Certification/Approval

All basins must be designed, stamped, and certified that they are built as designed by a N.C. registered professional. Wet detention ponds designed for projects in High Quality Waters, Outstanding Resource Waters, and Coastal Waters are reviewed and approved by staff in the DEM Regional Offices. Wet detention ponds designed for Watersupply watersheds will be reviewed and approved by the appropriate local government.

VIII. Definitions

1. **Forebay-** The forebay is an excavated settling basin or a section separated by a low weir at the head of the primary impoundment. The forebay serves as a depository for a large portion of sediment and facilitates draining and excavating the basin. Please see Figure 1.
2. **Plug flow-** Fluid particles pass through the basin and are discharged in the same sequence in which they enter. The particles remain in the tank for a time equal to the theoretical detention time. This type of flow is especially appropriate for basins with high length-to-width ratios (Metcalf and Eddy, Inc., 1979).
3. **Primary outlet-** The primary outlet is often constructed of a riser/barrel assembly and provides flood protection (i.e., for the 10-yr. storm) or reduces the frequency of the operation of the emergency spillway.
4. **Impervious surface-** Surfaces providing negligible infiltration such as pavement, buildings, recreation facilities, and covered driveways. This will include porous pavement, gravel, and precast concrete grid in most cases.

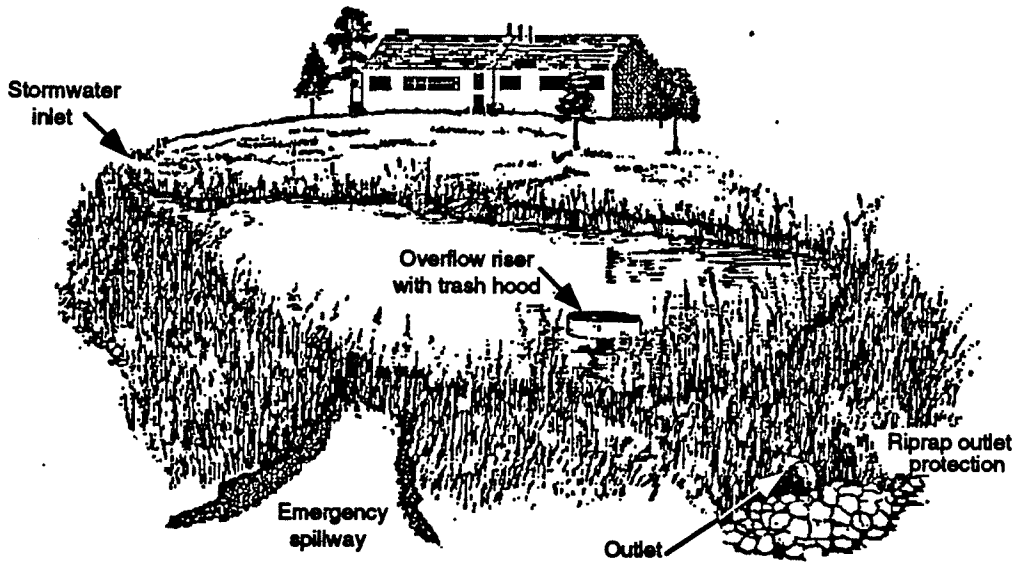
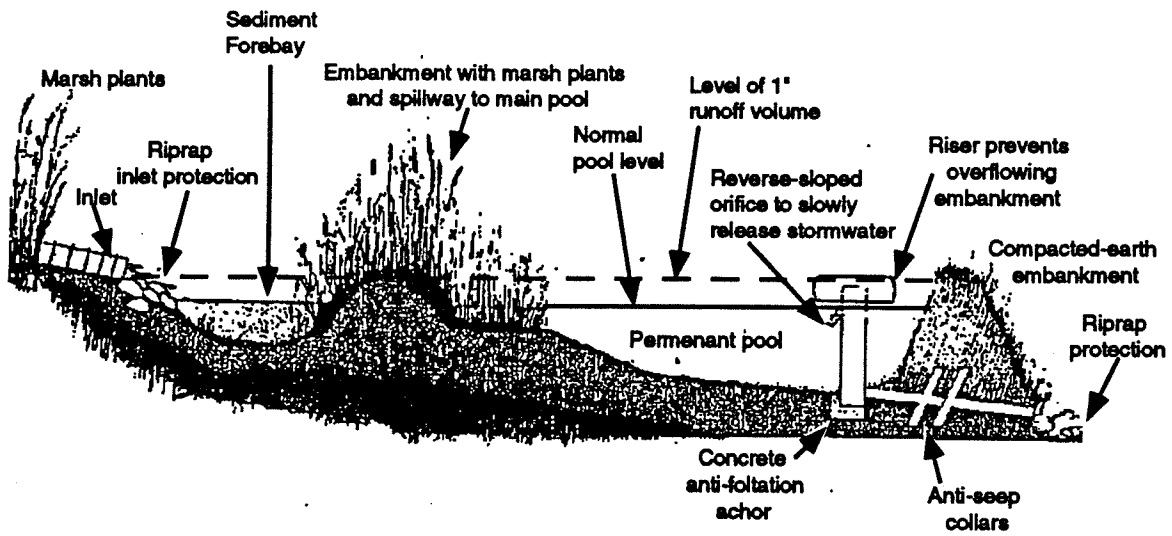

Figure 1. Wet Detention Pond Schematic (Stormwater Guidance Manual, NC, Arnold et. al.)

VIII. References

1. Andersen, L.W. 1970. Effects of Urban Development of Floods in Northern Virginia. United States Geological Survey. Water Supply Paper 2001-C. Washington, D.C.
2. Arnold, J.A., ed., D.E. Line, S.W. Coffey, and J. Spooner. 1993. Stormwater Management Guidance Manual. North Carolina Cooperative Extension Service and North Carolina Division of Environmental Management. Raleigh, N.C.
3. Barfield, B.J., R.C. Warner and C.T. Haan. 1981. Applied Hydrology and Sedimentology for Disturbed Areas. Oklahoma Technical Press, Stillwater, Oklahoma.
4. Brater, E.F. and H.W. King. 1976. Handbook of Hydraulics. 6th edition, McGraw-Hill, USA.
5. Charlotte Mecklenburg Stormwater Utilities, 1993, Charlotte Mecklenburg Storm Water Design Manual, July
6. Florida Department of Environmental Regulation, Nonpoint Source Management Section, Tallahassee, FL. 1984 Draft. The Florida Development Manual: A Guide to Sound Land and Water Management.
7. Florida Department of Environmental Regulation, Nonpoint Source Management Section, Tallahassee, FL. 1986. Current DER Criteria for Wet Detention Systems.
8. Harrington, B.W. 1987a. Design Procedures for Stormwater Management Extended Detention Structures. Maryland Department of the Environment, Sediment and Stormwater Division, Annapolis, MD.
9. Harrington, B.W. 1987b. Design Procedures for Stormwater Management Detention Structures. Maryland Department of the Environment, Sediment and Stormwater Division, Annapolis, MD.
10. Harrington, B.W. 1986. Feasibility and Design of Wet Ponds to Achieve Water Quality Control. Maryland Water Resources Administration, Sediment and Stormwater Division, Annapolis, MD.
11. Hartigan, J.P. 1986. Regional BMP Master Plans. In: Urban Runoff Quality- Impact and Quality Enhancement Technology. Urbonas, B. and L.A. Roesner, Eds. American Society of Civil Engineers, USA.
12. Hartigan, J.P. and T.F. Quasebarth. 1985. Urban Nonpoint Pollution Management for Water Supply Protection: Regional vs. Onsite BMP Plans. In: Proceedings of Twelfth International Symposium on Urban Hydrology, Hydraulics, and Sediment Control, University of Kentucky, Lexington, Kentucky, pp. 121-130.
13. James, W.P., J.F. Bell and D.L. Leslie. 1987. Size and Location of Detention Storage. Journal of Water Resources Planning and Management, 113(1): 15-28.
14. Janna, W.S. 1983. Introduction to Fluid Mechanics. Wadsworth, Inc., USA.
15. Leopold, L.B., M.G. Wolman and J.P. Miller. 1964. Fluvial Processes in Geomorphology. W.H. Freeman and Sons. San Francisco, CA.

16. Lindsley, R.K. and J.B. Franzini. 1972. *Water-Resources Engineering*. McGraw-Hill, USA.
17. Malcom, H.R., M.E. Avera, C.M. Bullard and C.C. Lancaster. 1986. *Stormwater Management in Urban Collector Streams*. Water Resources Research Institute of the University of North Carolina, Raleigh, NC. Report No. 226.
18. Malcom, H.R. and V.E. New. 1975. *Design Approaches For Stormwater Management in Urban Areas*, prepared for CE383 at NCSU, Raleigh, NC.
19. Maryland Department of Natural Resources, Sediment and Stormwater Division, Water Resources Administration, Annapolis, MD. 1986. *Maintenance of Stormwater Management Structures, A Departmental Summary*.
20. Maryland Department of Natural Resources, Sediment and Stormwater Division, Water Resources Administration, Annapolis, MD. 1987. *Guidelines for Constructing Wetland Stormwater Basins*.
21. McCuen, R.H. and G.E. Moglen. 1987. *Design of Detention Basins to Control Erosion*. Presented at Sediment and Stormwater Management Conference, Chestertown, Maryland. August 12, 1987.
22. McCuen, R.H. 1982. *A Guide to Hydrologic Analysis Using SCS Methods*. Prentice-Hall, Inc., Englewood Cliffs, New Jersey.
23. Metcalf and Eddy, Inc. 1979. *Wastewater Engineering: Treatment/Disposal/Reuse*. McGraw-Hill, USA, 920 pp.
24. Metropolitan Washington Council of Governments, Department of Environmental Programs. 1983. *Urban Runoff in the Washington Metropolitan Area, Final Report*. Prepared for US, EPA Nationwide Urban Runoff Program under Grant No. PO-003208-01.
25. North Carolina Department of Natural Resources and Community Development, Raleigh, NC. November 1, 1985. *Dam Safety. Title 15, Subchapter 2K*.
26. North Carolina Department of Natural Resources and Community Development, Raleigh, NC. August 1, 1985. *Sedimentation Control. Title 15, Chapter 4*.
27. North Carolina Department of Environment, Health, and Natural Resources, Division of Land Quality, Raleigh, NC. September 1988. *Erosion and Sediment Control Planning and Design Manual*.
28. Schueler, T.R. 1987. *Controlling Urban Runoff: A Practical Manual for Planning and Designing Urban BMPs*. Department of Environmental Programs, Metropolitan Washington Council of Governments.
29. Shaver and Maxted. 1993. *Construction of Wetlands for Stormwater Treatment*. Department of Natural Resources and Environmental Control. *Stormwater Design Manual. Chapter Six*.

30. United States Department of Agriculture, Soil Conservation Service, North Carolina. 1987. Pond. Technical Guide, Section IV, No. 378-1.
31. United States Department of Agriculture, Soil Conservation Service. 1986. Engineering Field Manual for Conservation Practices.
32. United States Department of Agriculture, Soil Conservation Service. 1986. Urban Hydrology for Small Watersheds. Technical Release No. 55.
33. United States Department of Agriculture, Soil Conservation Service. 1970. Soil Survey, Wake County, North Carolina.
34. United States Department of Agriculture, Soil Conservation Service. National Engineering Handbook.
35. United States Department of Commerce, Bureau of Public Roads. December 1965. "Hydraulic Charts for the Selection of Highway Culverts," Hydraulic Engineering Circular No. 5, USGPO, Washington, D.C.
36. United States Environmental Protection Agency. 1986. Methodology for Analysis of Detention Basins for Control of Urban Runoff. EPA 440/5-87-001.
37. United States Environmental Protection Agency. 1983. Final Report of the Nationwide Urban Runoff Program, Volume 1.
38. Urbonas, B. and W.P. Ruzzo. 1986. "Standardization of Detention Pond Design for Phosphorus Control." In Urban Runoff Pollution. Ed. by H.C. Torno, J. Marsalek and M. Desbordes. NATO ASI Series, Vol. G10. Springer-Verlag, New York, New York.
39. Viessman, W. Jr., J.W. Knapp, G.L. Lewis and T.E. Harbaugh. 1977. Introduction to Hydrology. Harper and Row, Publishers, Inc., New York, New York.

Chapter 2 Stormwater Wetlands

I. Introduction

Stormwater wetlands can be defined as constructed systems that are explicitly designed to mitigate the impacts of stormwater quality and quantity that occur during the process of urbanization. They do so by temporarily storing stormwater runoff in shallow pools that create growing conditions suitable for emergent and riparian wetland plants. The runoff storage, complex microtopography and emergent plants in the stormwater wetland together form an ideal matrix for the removal of urban pollutants.

Stormwater wetlands, in North Carolina, will initially describe two basic designs; extended detention wetlands, and pocket wetlands. The first type, an extended detention wetland, is very similar in design to that of a wet detention pond, as described in the previous section. In extended detention wetlands, extra runoff storage is created above the shallow marsh by temporary detention of stormwater runoff. The basic differences between the design of a wet detention pond and that of an extended detention stormwater wetland is that the depth of the permanent pool of water in an extended detention wetland should be limited to 3 feet, and a larger area of the BMP is designed to be at normal depths of zero to one foot. When designed and constructed to the guidelines described here, an extended detention wetland is assumed to achieve the required 85% TSS removal.

The second type of wetland that will initially be allowed in North Carolina is the pocket wetland. Pocket wetlands are well adapted to serve smaller sites and when used in combination with filter strips and grassed swales. They differ in design from extended detention basins in that they have a smaller permanent pool of water, and a forebay will not be required if the pocket wetland is being fed stormwater from a grassed swale or vegetated filter strip designed according to the standards explained in Chapters 5 and 7 respectively. Because they are less efficient in removing pollutants from stormwater runoff, they must be used in combination with other BMPs to achieve the desired 85% TSS removal.

II. General Characteristics

It is important to note what stormwater wetlands are not. Stormwater wetlands are not typically located within delineated natural wetland areas. Natural wetlands provide critical habitat and ecosystems services, are protected under state and federal statute. Stormwater wetlands should not be confused with created wetlands that are used to mitigate for the loss of natural wetlands under permitting provisions of wetland protection requirements. The primary goal of wetland mitigation is to replicate the species diversity and ecological function of the lost natural wetland; whereas, the more limited goal of stormwater wetlands is to maximize pollutant removal and create generic wetland habitat.

Stormwater wetlands also should be distinguished from natural wetlands that receive stormwater runoff as a consequence of upstream development. Although not intended for stormwater treatment, stormwater-influenced wetlands are very common in urban settings. When stormwater runoff becomes a major component of the water balance of a natural wetland, its functional and structural qualities can be severely altered. The end result is that a stormwater-influenced wetland ultimately shares more of the characteristics of a stormwater wetland than a natural wetland.

Figure 2, Extended Detention Stormwater Wetland, From Design of Stormwater Wetland Systems, Schueler, 1992

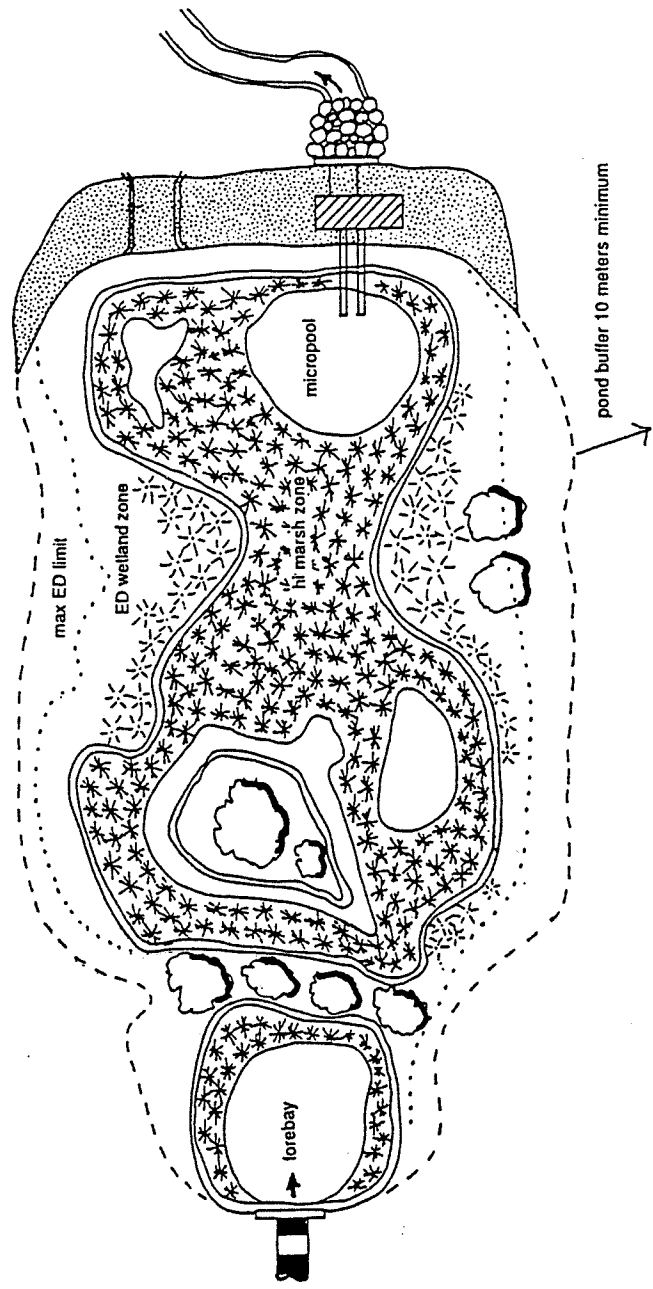
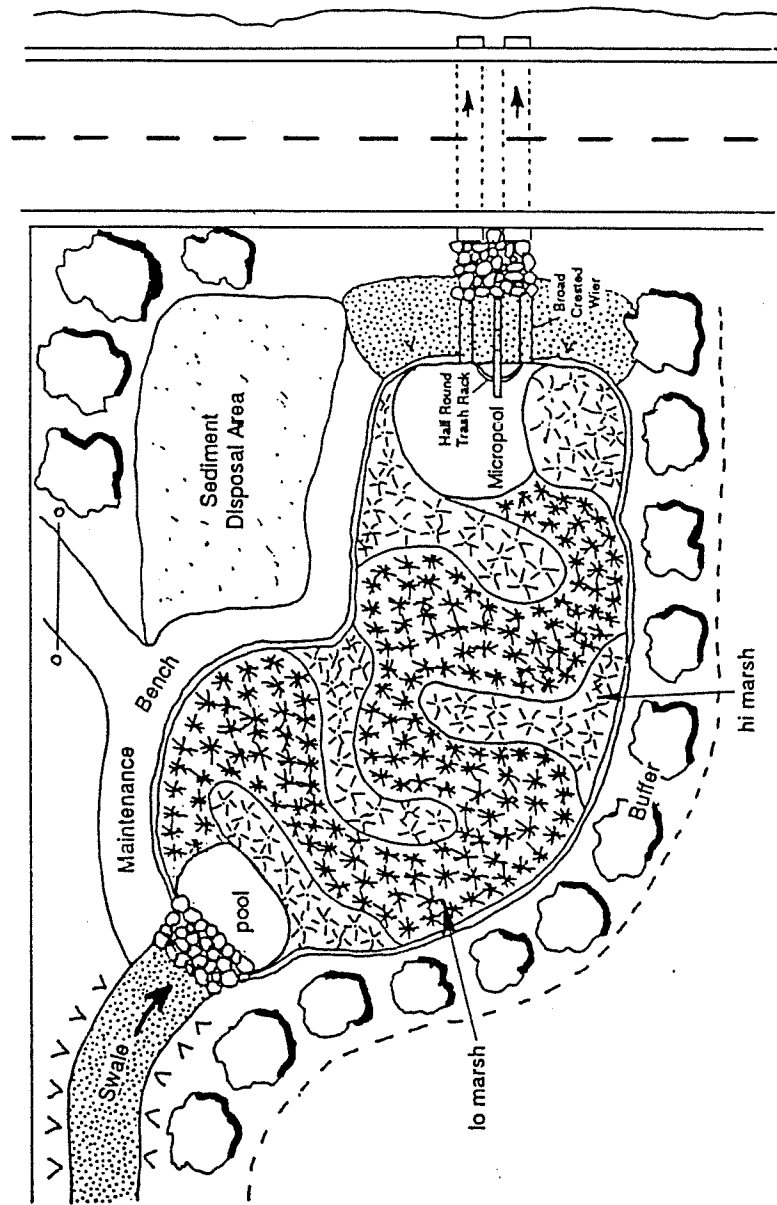

Figure 3, Stormwater Pocket Wetland, From Design of Stormwater Wetland Systems, Schueler, 1992



The differences in natural wetlands and wetlands constructed for the purpose of treating urban stormwater runoff are great, and range from the amount of time the area is inundated to the sediment loads they experience. The following table is a summary of the major differences:

Table II.1	
Differences Between Stormwater Wetlands and Natural Non-tidal Wetlands Within the Mid-Atlantic Region	
Stormwater Wetlands	Natural Wetlands
Water balance dominated by surface runoff	Water balance often an expression of groundwater
Hydroperiod is "semi-tidal"; inundation and rapid drawdown 10-30 times/year	Hydroperiod is more gradual and may change on a seasonal basis
Standing water present year round	Standing water may only be present on a seasonal basis
Wetland boundaries clearly defined	Wetland boundaries may adjust on a seasonal basis due to groundwater shifts
Species diversity established by human design or by volunteers; no prior seedbank	Species diversity maintained by seedbank
Simple topographic structure	Complex topographic structure
Relatively few species, dominated by emergent types	Diverse number of species, with a mix of tree, shrub, herbaceous, and emergent types
Prone to colonization by invasive species such as Typha and Phragmites	Fewer exotic and dominant species, unless site and been disturbed
System requires maintenance	Self-maintaining system
Sediments and water columns enriched with nutrients and trace metals, higher turbidity	Lower quantities of pollutants in the wetland, lower turbidity
High rates of sediment supply	Lower rate of sediment supply
Low to moderate wildlife habitat potential	Moderate to high wildlife habitat value
Note: Natural wetlands that receive urban stormwater input (i.e. stormwater influenced wetlands) will share characteristics of both types	
Table from: <u>Design of Stormwater Wetlands Systems: guidelines for creating diverse and effective stormwater wetlands in the mid-Atlantic Region</u> , Schueler	

III. Advantages

The basic intent of a stormwater wetland is to create a shallow matrix of sediment, plants, water and detritus that collectively removes multiple pollutants through a series of complementary physical, chemical and biological pathways. Sheet flow conditions across a wetlands, slower velocities and the hydraulic

resistance afforded by the wetland vegetation work together to provide very good conditions for particle settling. The emergent plants that greatly characterizes stormwater wetlands help to stabilize the sediments that settle and thereby reduce the amount of resuspension. Because stormwater wetlands are relatively efficient in removing sediment from the water column, they are also relatively efficient at removing those pollutants, such as phosphorus, trace metals, and hydrocarbons, that are adsorbed to the surfaces of suspended particles. The plants that so characterize a stormwater wetland can also be an advantage when considering aesthetics. Properly landscaped and maintained, a stormwater wetland can provide a natural, park like setting.

Another advantage of stormwater wetlands is that of increased biological uptake, from both emergent plants and algae. Stormwater wetlands, by design, focus on providing a greater interactions with emergents and longer contact times. While most aquatic plants take up nutrients from the bottom sediments, this does remove nutrients from the sediment and they are mostly reintroduced to the water column at times when they will cause few problems.

Another advantage that is applicable to the pocket stormwater wetland is that they are appropriate for smaller sites where a full, extended detention wetland or wet detention ponds might not be appropriate.

IV. Disadvantages

The main disadvantage to stormwater wetlands, and to extended detention wetlands in particular, is that they occupy more land than other stormwater BMPs. This is especially a problem for developments where most of the land will be used for development and the ultimate amount impervious surface will be greater than 70% of the site area.

Extended detention wetlands that are sited in watersheds that are too small will tend to dry out more frequently, and these can become a nuisance. In most cases this can be avoided by proper sizing, and providing a drainage area of not less than 10 acres. The volume of most stormwater wetlands is such that they flush water through them with one week and thus do not become problem areas for mosquito breeding.

Another disadvantage is the difficulty, at times, in finding sources for the wetland plant material. This situation is changing, as more commercial nurseries are stocking native wetland plants. If the designer has trouble finding supplies, it is suggested that they contact a landscape architect that has experience in wetland mitigation.

V. Costs

Costs to design and construct stormwater wetlands systems will vary widely, but for most systems will be similar to those of wet detention basins. The costs could be increased because of the need to excavate a larger area, but could be decreased because excavation would not need to be as deep.

VI. Design Requirements

Extended Detention Wetlands

The design for extended detention wetlands is very similar to that of the wet detention basins as described in the previous chapter. The permanent pool of water should be sized as one would using Table 1.1 with a permanent pool depth of 3 feet. The additional requirement of the detention of the runoff from the 1" storm for a period of 2 to 5 days still applies and this volume will be the volume above the permanent pool. An extended detention wetland must be also be designed with a forebay, as is a wet detention pond.

The major difference between an extended detention wetland and a wet detention pond is that the allocation of surface area to different pond depths. For the system to function as a wetland 70% of the area of the permanent pool needs to be designed as a marsh with a depth of 0 to 18", with an almost equal distribution of area (35% and 35%) between 0" to 9" and 9" to 18." The other major difference is that there needs to be a small pool (15% of the surface area) where the outlet is located.

A most important consideration when designing both extended detention wetland systems and pocket wetland systems is the specification and installation of plants. Tables IV.1, IV.2, and IV.3 will give a good indication of those plants that can be used in areas that will not be continually inundated. The ponding times, shown in days under Ponding, will give a good indication of what zones of the wetland the species should be planted. Shown below in Table II.2 are those plants that should do well when planted within the normal, permanent pool of the wetland.

Scientific Name Common Name	Form	Commercial Availability	Inundation Tolerance	Wildlife Value	Notes
<i>Peltandra virginica</i> Arrow arum	Emergent	yes	up to 1 ft.	High, Berries are eaten by wood ducks	Full sun to partial shade
<i>Sagittaria latifolia</i> Arrowhead/ Duck potato	Emergent	yes	up to 1 ft.	Moderate. Tubers and seeds eaten by ducks	Aggressive colonizer
<i>Andropogon virginicus</i> Broomsedge	Perimeter	yes	up to 3 in.	High. Songbirds and browsers. Winter food and cover	Tolerant of fluctuating water levels & partial shade
<i>Andropogon glomeratus</i> Bushy Beardgrass	Emergent	yes	up to 1 ft.		Requires full sun
<i>Typha spp.</i> Cattail	Emergent	yes	up to 1 ft.	Low. Except as cover	Aggressive. May eliminate other species. Volunteer. High pollutant treatment.
<i>Ceratophyllum demersum</i> Coontail	Submergent	yes	yes	Low food value. Good habitat and shelter for fish and invertebrates	Free floating SAV. Shade tolerant. Rapid growth.
<i>Scirpus pungens</i> Common Three-Square	Emergent	yes	up to 6 in.	High. Seeds, cover. Waterfowl, songbirds	Fast colonizer. Can tolerate periods of dryness. Full sun. High metal removal.
<i>Lemna spp.</i> Duckweed	Submergent/ emergent	yes	yes	High, Food for waterfowl, and fish	High metal removal
<i>Saururus cernuus</i> Lizard's tail	Emergent	yes	up to 1 ft.	Low, except for wood ducks	Rapid growth. Shade tolerant.
<i>Hibiscus moscheutos</i> Marsh Hibiscus	Emergent	yes	up to 3 in.	Low. Nectar.	Full sun. Can tolerate periodic dryness
<i>Pontederia cordata</i> Pickerelweed	Emergent	yes	up to 1 ft.	Moderate. Ducks. Nectar for butterflies.	Full sun to partial shade
<i>Potamogeton pectinatus</i> Pond Weed	Submergent	yes	yes	Extremely high. Waterfowl, marsh and	Removes heavy metals.

				shorebirds.	
<i>Leersia oryzoides</i> Rice cutgrass	Emergent	yes	up to 3 in.	High. Food and cover.	Full sun although tolerant of shade. Provides some shoreline stabilization
<i>Carex spp.</i> Sedges	Emergent	yes	up to 3 in.	High, Waterfowl and songbirds.	Many wetland and several upland species.
<i>Scirpus validus</i> Soft-stem Bulrush	Emergent	yes	up to 1 ft.	Moderate. Good cover and food.	Full sun. Aggressive weedy aliens such as <i>P. perfoliatum</i>
<i>Polygonum spp.</i> Smartweed	Emergent	yes	up to 1 ft.	High. Waterfowl, songbirds. Seeds and cover.	Fast colonizer. Tolerant of fluctuating water levels.
<i>Juncus effesus</i> Soft Rush	Emergent	yes	up to 1 ft.	Moderate.	Tolerates wet or dry conditions.
<i>Nuphar luteum</i> Spatterdock	Emergent	yes	up to 3 ft.	Moderate for food but high for cover.	Fast colonizer. Tolerant of fluctuating water levels.
<i>Panicum vergatum</i> Switchgrass	Perimeter	yes	up to 3 in.	High. Seeds, cover for waterfowl and songbirds.	Tolerates wet and dry conditions.
<i>Acorus calamus</i> Sweet Flag	Perimeter	yes	up to 3 in.	Low.	Tolerant of dry periods. Not a rapid colonizer. Tolerates acidic conditions
<i>Elodea canadensis</i> Waterweed	Submergent	yes	yes	Low.	Good water oxygenator. High nutrient, copper, manganese and chromium removal.
<i>Valisneria americana</i> Wild Celery	Submergent	yes	yes	High. Food for waterfowl. Habitat for fish and invertebrates.	Tolerant of murky water and high nutrient loads.
<i>Zizania aquatica</i> Wild rice	Emergent	yes	up to 1 ft.	High. Food for birds.	Prefers full sun.
Table from: <i>Design of Stormwater Wetlands Systems: guidelines for creating diverse and effective stormwater wetlands in the mid-Atlantic Region</i> , Schueler					

Pocket Wetlands

In those situations where a combination of stormwater BMPs will be utilized to achieve the required 85% TSS removal, pocket wetlands in combination with grassed swales or filter strips can provide the needed removal. For design purposes these can be thought of as a special case of the extended detention wetland, or possibly a small wet detention pond with special emphasis placed on the wetland plantings. The sizing process should follow that of the wet detention basin, but with the following table, Table II.3 used in place of Table I.1. For example, a development of 4.5 acres, with 3.825 acres of imperviousness (85% Imperviousness) would need a pocket wetland that had 0.96% of 4.25 acres of permanent pool. One notable difference between this table and Table I.1 is that no depths are given. An average depth of two feet is assumed.

Imperviousness (%)	SA/DA (%)
< 70	0.75
70	0.80
75	0.85
80	0.91
85	0.96
90	1.02
95	1.07
100	1.12

- Pocket wetlands must capture the runoff from the 1 yr., 24 hour storm and release it over a period of 48 hours, or
- Capture the runoff from the 1 inch storm and allow it to draw down over a period of 2 to 5 days.
- Average depth of no more than 2 feet.
- Pond area depth distribution should be as follows:
 - High Marsh (0 - 6" in. depths) = 50% of surface area of permanent pool
 - Low Marsh (12 to 6' depths) = 40%
 - Open water (> 18" depth) = 10%
- Cleanout access must be provided that is sufficient for heavy machinery.
- There should be a drain that will completely empty the basin for cleanout.
- Any additional peak flow control that the local government requires must be met.
- If the wetland was used during construction as a sediment basin or trap, then the basin must be cleaned out, graded, and vegetated within 14 days of the completion of construction.
- There must be a vegetation planting plan prepared by a NC licensed professional. Special consideration must be given to the species specified due to the frequent inundations.
- Source of wetland materials must be specified in planting plan
- The wetland must be stabilized with 14 days of construction. This might be in the form of final vegetation, or a temporary means of providing stabilization till the vegetation becomes established.
- Inlet and outlet channels should be protected from scour during high flows from large storms. Standard erosion control measures work very well. The Land Quality Section of the North Carolina Department of Health, Environment, and Natural Resources and the US Department of Agriculture Natural Resource Conservation Service (SCS) can provide valuable information on erosion and sediment control techniques.

Additional Design Considerations:

- Sediments can be resuspended by the incoming runoff. Therefore it is recommended that there be either an additional plunge pool at the inlet of the basin, or sufficient measures such as riprap to disperse the energy.
- A forebay to capture sediment can minimize cleanout problems. It is a good idea to provide adequate access for equipment to be used for cleanout. Also, paving or flexible revetment in the forebay can allow for rapid access and quick sediment removal by heavy equipment. Pocket wetlands that receive runoff from anything other than vegetated filters or swales should incorporate forebay.

VII. Maintenance

Pocket wetlands that have no sediment pretreatment will tend to accumulate sediment very rapidly and therefore will need cleanout when they accumulate six inches of deposition, which in most cases will take 5 to 10 years. An on-site sediment disposal area should be seriously considered for any pocket wetland, and should be sized to receive three cleanout cycles.

Due to their small size, pocket wetlands can be mucked out with a portable mudcat or backhoe. The top few inches of sediment should be stockpiled, so that it can be replaced over the surface of the wetland after the completion of sediment removal to reestablish through its own seedbank.

Maintenance Requirements are as follows:

- Pocket Wetlands will tend to collect debris, and it should be removed whenever it accumulates, or at least twice annually.
- Wetland should be inspected annually after a rain event to ensure that the basin is operating as designed.
- At a minimum, items that should be included in the inspection are:
 1. clogging of the outlet or too rapid a release,
 2. erosion on the banks,
 3. erosion at the inlet and outlet,
 4. sediment accumulation and the need for removal,
 5. condition of the emergency spillway, and
 6. woody vegetation in the embankment.

VIII. Peak Flow Reduction

As with a normal wet detention pond, the pocket wetland must capture the runoff from the first inch of rain, and release it over a period of 2 - 5 days. In this case it is recommended that the designer should configure the outlet such that this water quality design storm should draw down within approximately 48 hours. This will broaden the range of wetland species that will tolerate the condition that will occur just above the permanent pool.

IX. References

1. Driscoll, E.D. 1986. Detention and Retention Controls for Urban Runoff. Urban Runoff Quality: Impact and Quality Enhancement Technology. B. Urbonas and L. Roesner, editors. American Society of Civil Engineers.
2. Livingston, E. H. 1988. The Use of Wetlands for Urban Stormwater Management. Design of Urban Runoff Quality Controls, Engineering Foundation Conference proceedings. Roesner, L.A., B. Urbonas, and M.B. Sonnen. editors.
3. Shaver, E. and J. Maxted. Construction of Wetlands for Stormwater Treatment, Delaware Department of Natural Resources and Environmental Control. 1993

4. Shueler, T.R., P.A. Kumble, and M.A. Heraty. 1992. A Current Assessment of Urban Best Management Practices: Techniques for Reducing Non-Point Source Pollution in the Coastal Zone. Publication number 92705. Metropolitan Washington Council of Governments. Washington, D.C. 127. pp.
5. Shueler, T. R. 1987. Controlling Urban Runoff: A Practical Manual for Planning and Designing Urban BMPs. Publication number 87703. Metropolitan Washington Council of Governments, Washington, D.C. 275 pp.
6. U.S. EPA. 1990. Water Quality Standards for Wetlands. Office of Water Regulations and Standards. (WH-585), EPA 440/S-90-011
7. Urbonas, B. and L.A. Roesner, eds. 1986. Urban Runoff Quality -- Impact and Quality Enhancement Technology. American Society of Civil Engineers. New York, NY. 477 pp.
8. Urbonas, B. and W.P. Ruzzo. 1986. "Standardization of Detention Pond Design for Phosphorus Control." In Urban Runoff Pollution. Ed. by H.C. Torno, J. Marsalek and M. Desbordes. NATO ASI Series, Vol. G10. Springer-Verlag, New York, New York.

Chapter 3 Sand Filters

I. Introduction

It is understood that many development projects present a challenge to the designer of conventional stormwater BMPs, such as wet detention ponds, because of physical constraints, such as layout of the site and topographical relief of the site. Many of these siting problems of wet detention ponds can be overcome if the issue of stormwater quality treatment is addressed at the very first stages of development planning. For those sites where significant spatial limitations cannot be overcome, one or a combination of the following BMPs can provide the water quality benefit that is required.

Sand filters and bioretention areas, are intended to address the spatial constraints that can be found in intensely developed urban areas where the drainage areas are highly impervious. Both can be used on small, urban sites that would not normally support the hydrology of a wet detention pond and where the soils would not support an infiltration device. They are filtration systems with the bioretention areas providing some nutrient uptake and groundwater recharge. The following are guidelines for the siting, construction, and maintenance of these stormwater BMPs.

The design procedure described here is based on the experience and equations that were developed by the City of Austin, TX., the State of Maryland, and the State of Delaware. Much appreciation is extended to Earl Shaver of the Delaware Department of Natural Resources for the use of much his design guidance.

While sand filters are new in the area of stormwater treatment, they have been used for many years to treat wastewater and as part of the process of purifying drinking water. In most cases, monitoring results suggest that sand filters used to treat stormwater behave similarly to sand filters used in wastewater treatment. They have been demonstrated to be effective in removing many of the common pollutants found in urban stormwater runoff, especially those found in particulate form. They have also been shown to have at least a moderate level of bacterial removal. They have not been effective at removing total dissolved solids and nitrate-nitrogen and, for this reason, would best be used upstream of a vegetated filter.

There are two basic components of a sand filter design: the sediment chamber and the sand chamber. They both are both important parts of the design, and neither can be omitted. The purpose of the sediment chamber is to reduce the amount of sediment that reaches the sand chamber and to help ensure that stormwater reaches the sand chamber as sheet flow. The purpose of the sand chamber is to trap the finer sediment and sediment bound pollutants, and to provide a media for microbial removal of bacteria.

Sand filters work by receiving the first flush of runoff and settling out the heavier sediment in the sediment chamber. Water then flows to, and is spread over the sand bed where pollutants are either trapped or strained out. Sand filters are to be used only for drainage areas that have been stabilized. Sediment suspended in runoff during construction could quickly clog the sand filter and render it useless. By excluding disturbed areas draining to the sand filter, the actual pollutant loadings that must be treated by the sand filter are those generated by the land use activity for which it is designed. Drainage areas directed to each sand filter should be kept below 5 acres in size. Larger drainage areas are less likely to be entirely impervious, and it is more difficult to distribute the flow of runoff across the sand bed. Sand filter systems can be used on large parking areas and other sites larger than 5 acres if the site is divided into smaller drainage areas that feed individual sand filters.

Sand filters are intended primarily for water quality enhancement and must be designed to handle the runoff from frequent storm events. They must be designed to accommodate all the runoff which drains to them, so

the drainage area must be determined for actual design. For the State of North Carolina, water quality controls must be designed for 85% removal of Total Suspended Solids. Design for this level of treatment requires the bulk of TSS removal occur on the frequent, smaller volume storms. Sand filter systems designed according to the requirements outlined here for control of the first inch of runoff are considered to meet the 85% TSS removal requirement. In most of North Carolina, this represents the runoff of over 90% of all storm events.

II. Design Requirements

Sediment Chamber:

- Volume = 540 ft³ per acre of drainage area
- At least 18 inches deep
- A surface area of at least 360 ft²
- Positive drainage to this chamber either in conduit or surface drainage
- No outlet except to sand chamber
- Outlet to the sand chamber to result in sheet flow

Sand Filter:

- Volume = 540 ft³ per acre of drainage area
- At least 18 inches of sand particles less than 2 mm average diameter
- A surface area of at least 360 ft²
- An outlet positioned and sized such that the sand chamber will drain completely in 24 hours
- No single outlet pipe sized greater than 6 inches, in order to provide a minimum of 12 inches of sand above pipe

General:

- Access to both chambers must be sufficient for all maintenance activities. Because the sediment from at least the first chamber will be somewhat wet when maintenance occurs, heavy equipment access should be provided.
- The filter must be designed to structurally withstand any load that is expected to occur, both in terms of water quantity and sediment quantity.

The design parameters above assume an average filtration rate of 0.04 gal/min/ft² with one foot of head on the sand surface. This rate is needed in order to allow the first inch of runoff to pass through the filter within a period of 24 hours. The effect of this is that each square foot of sand must transmit approximately 62 gallons of water over a period of 24 hours. This design assumes that drainage through the sand chamber will be occurring throughout the duration of runoff. Storms that exceed one inch of runoff may, depending on their intensity and duration, overflow the sand filter. In these situations, runoff may not receive the same level of treatment as runoff from smaller storms. In situations where a stormwater quantity control is required, runoff that will flow over the sand filter must be considered in addition to the water flowing from the normal outlet from the sand filter.

Two examples of sand filters are shown below. The first example, Figures 4 and 5, is one that might be used in an area where land values are very high, or where there are severe physical limitations in siting a BMP. This design uses a concrete structure and can be located or constructed in such a way as to occupy no developable land. The second, Figure 6, is an example of a sand filter that might be used on a project where spatial limitations are present, but there is some land available for stormwater management. This

design does not use the same precast-concrete structure that is used above, and would be less expensive to construct, but would take more land area than the first design presented.

Figure 4, Delaware Sandfilter, From Shaver 1992

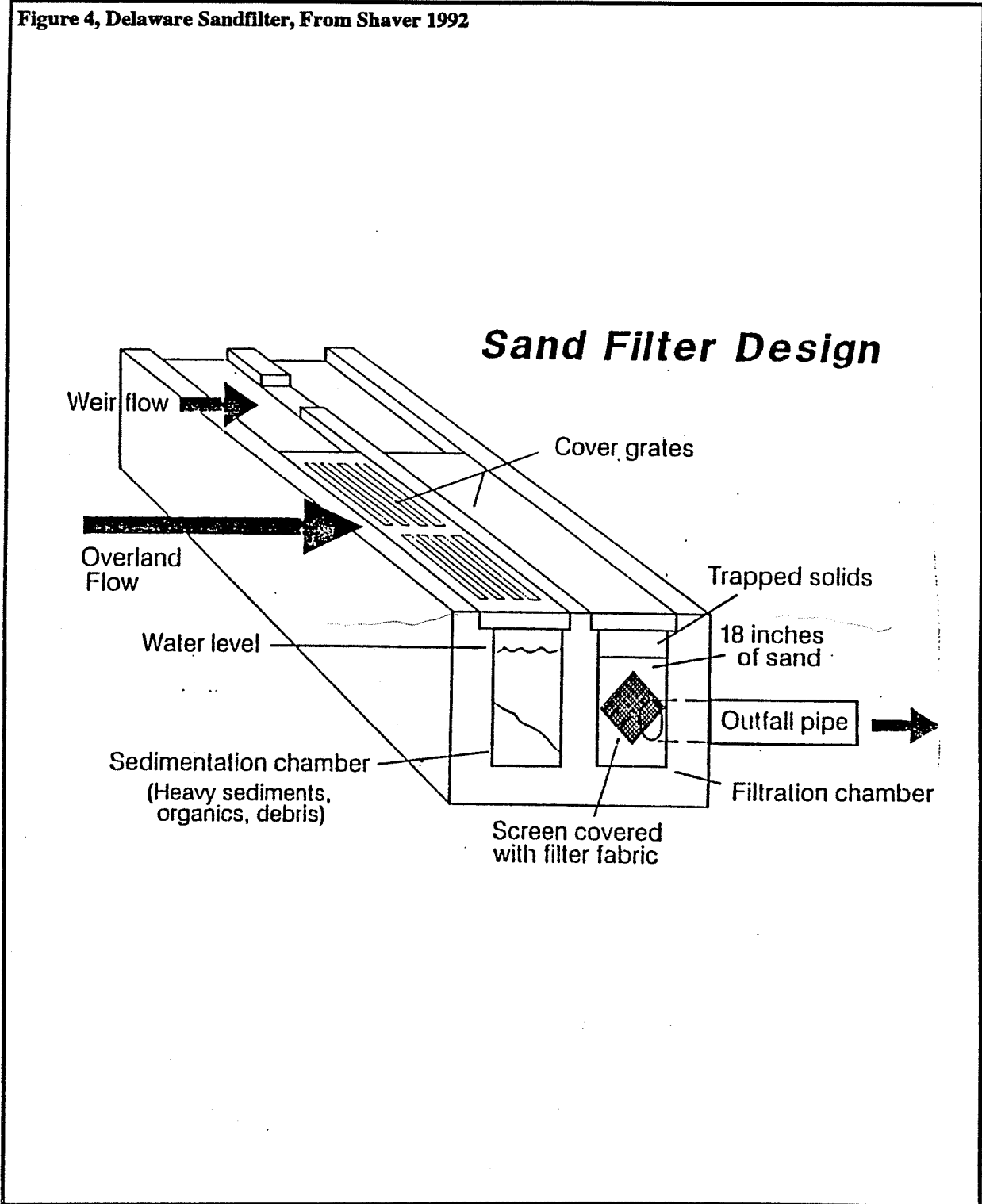

Figure 5, Sandfilter Schematic, From Shaver, 1992

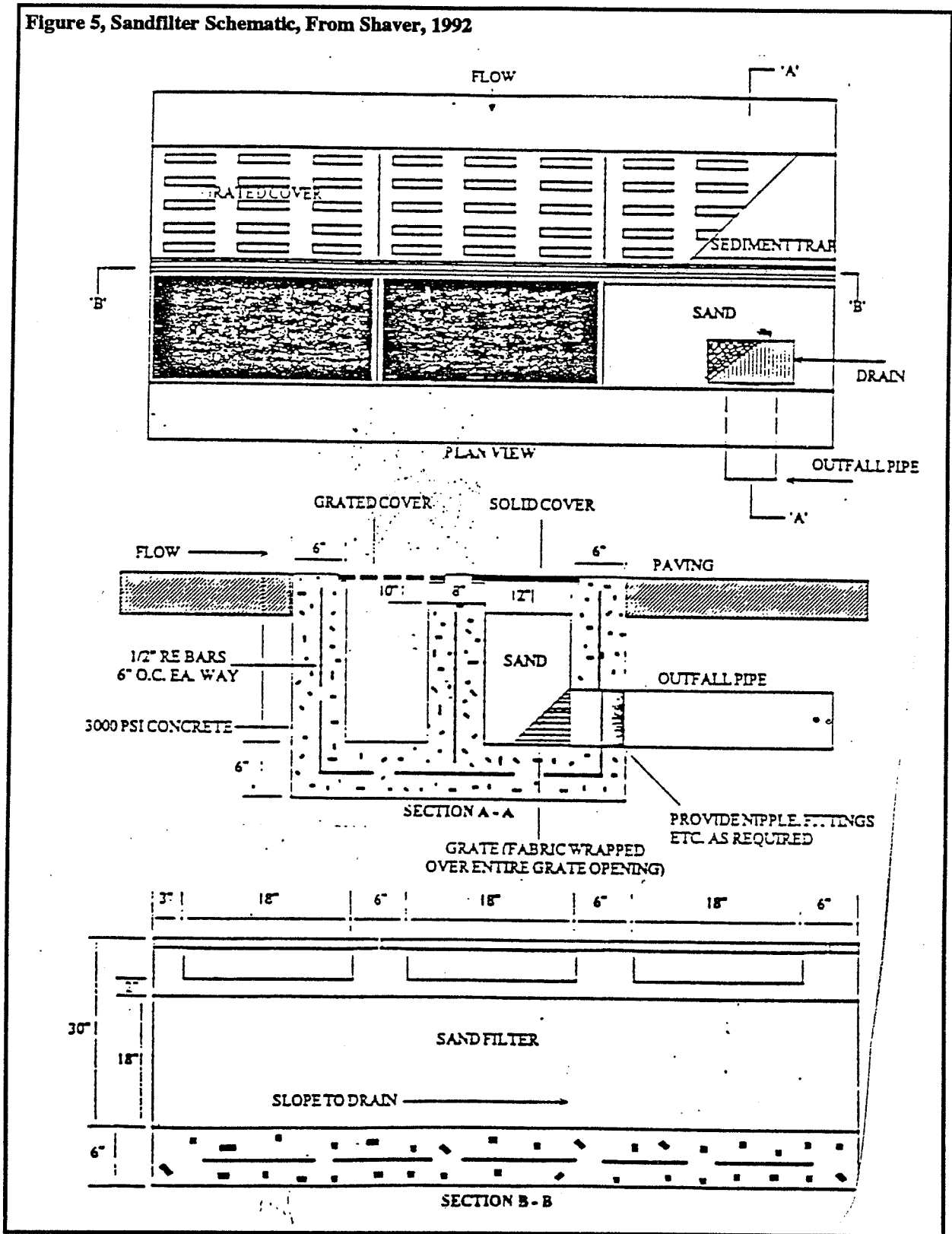
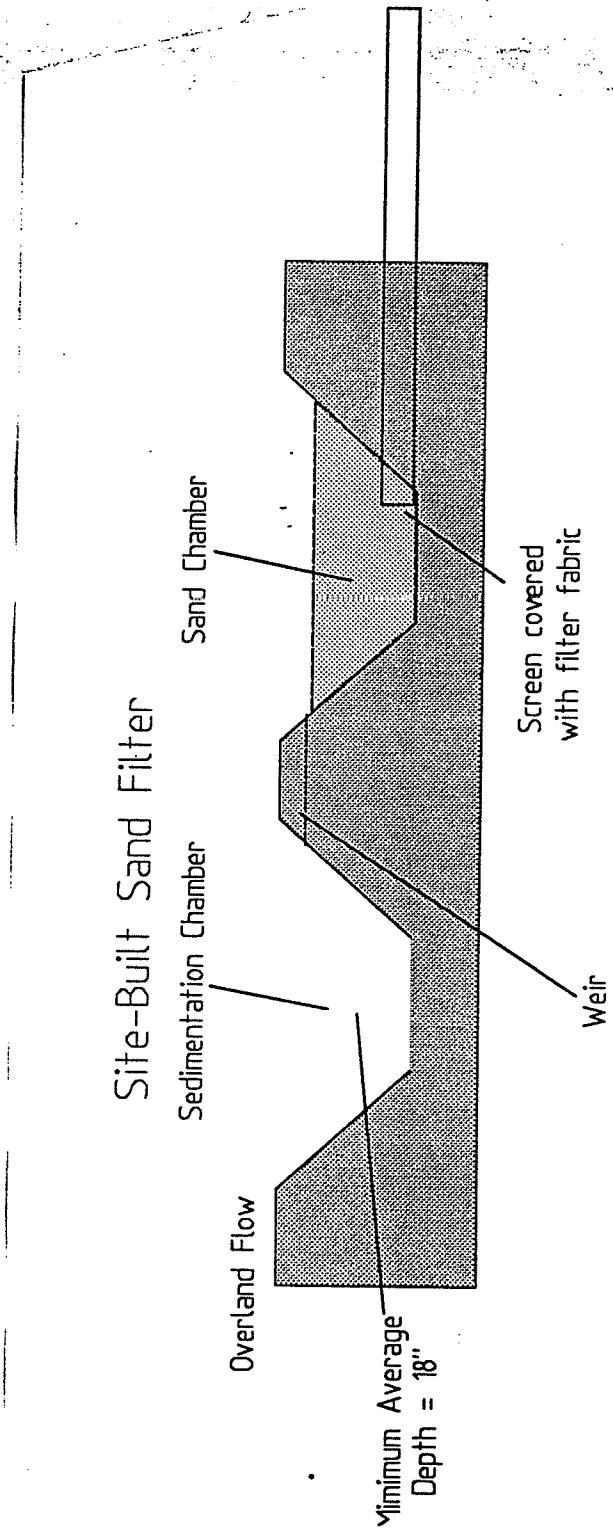

Figure 6, Modified Delaware Sandfilter Design Schematic



III. Maintenance

Regular maintenance is essential to the long-term performance and durability of the sandfilter, as it is with all stormwater BMPs. At least once a year each filter must be inspected after a storm to determine if the filter bed is passing the runoff as expected. Depending mostly on the activities occurring in the drainage area, most filters will show some decreased capacity for filtration after a few years. Maintenance operations must be performed when storms of approximately one inch are not passing through the filter within 24 hours. Maintenance for sand filters consists of removing the first two or three inches of discolored sand, and replacing this with new sand. The sand that has been removed would then be dewatered, if necessary, and then landfilled. At the same time that maintenance is performed on the sand chamber, the sediment chamber should also be pumped and cleaned. It is most likely that the sediment removed from the first chamber will need to be dewatered before it is allowed to be dumped at a landfill.

Chapter 4 Bioretention Areas

I. Introduction

It is understood that many development projects present a challenge to the designer of conventional stormwater BMPs, such as wet detention ponds, because of physical constraints, such as layout of the site and topographical relief of the site. Many of these siting problems of wet detention ponds can be overcome if the issue of stormwater quality treatment is addressed at the very first stages of development planning. For those sites where these significant spatial limitations cannot be overcome, one or a combination of the following BMPs can provide the water quality benefit that is required.

Sand filters and bioretention areas, are intended to address the spatial constraints that can be found in intensely developed urban areas where the drainage areas are highly impervious. Both can be used on small, urban sites that would not normally support the hydrology of a wet detention pond and where the soils would not support an infiltration device. They are filtration systems with the bioretention areas providing some nutrient uptake and groundwater recharge. The following are guidelines for the siting, construction, and maintenance of these stormwater BMPs.

The design procedure described here is based on a manual published by the Prince George's County, Maryland (Design Manual for Use of Bioretention in Stormwater Management, for Prince George's County, Maryland.) Text and graphics are used from this manual with their permission. If further guidance is needed for this BMP, there are limited supplies of this manual available from the Division of Environmental Management, Water Quality Section.

Bioretention is a water quality practice developed by the Prince George's County, Maryland, Department of Environmental Resources using plants and soils for removal of pollutants from stormwater runoff. Bioretention employs various physical and biological processes in the water quality treatment of runoff. These processes include adsorption, filtration, volatilization, ion exchange, and decomposition. Biological systems have been widely used in retention and transformation of nutrients found in agricultural and sewage treatment waste. Bioretention was developed to have a wide range of applications for various considerations which include:

- site conditions,
- land uses,
- soil types,
- stormwater pollutants, and
- wet or dry conditions.

Numerous studies have documented the pollutant loading/water quality impacts of development. These studies have shown that the amount of pollutant runoff, in the form of sediment, nutrients (primarily nitrogen and phosphorus), oil and grease, and trace metals, increases substantially following the development of a site. Pollutant loadings are concentrated in the "first flush" of runoff from impervious areas. Bioretention areas are an off-line system used in the treatment of the "first flush." Pollutant removal is performed through physical and biological treatment processes occurring in the plant and soil complex including transpiration, evaporation, storage, and nutrient uptake.

There are many potential side benefits to the use of plant based BMPs other than water quality treatment. Planting systems, if sited properly, can improve the landscape value of the site, provide shade and wind breaks, and absorb noise.

The purpose of this chapter is to provide guidelines for the creation of bioretention areas within the design of stormwater management practices for development sites. Presented in the next section are the overall bioretention area layout and explanation of the functions of the components of bioretention systems. Schematic illustrations are given for several types of bioretention practices for use in green space areas of sites. Guidelines for site grading and planting plans are presented in Sections III and IV, respectively. Soil and organic layer considerations are discussed in Section V. Maintenance requirements for bioretention areas are discussed in Section VI. Section VII presents the methodology for computing the level of pollutant reduction which may be achieved as a result of implementation of bioretention practices at a site.

II. The Bioretention Concept

A conceptual illustration for the bioretention water quality control practice is presented in Figure 7. The bioretention area design provides infiltration and water storage for uptake by vegetation. Figure 7. shows the sheet flow runoff from an impervious surface (such as a parking lot) discharge into the bioretention area through a grass buffer strip. The runoff is then infiltrated into a planting media. Once the infiltration capacity of the planting soil is exceeded, stormwater is discharged at the surface of the planting soil.

The surface of the planting soil is depressed to allow for some ponding of the runoff. The runoff is infiltrated through a surface organic layer of mulch and/or a ground cover to the planting soil. The runoff is stored in the planting soil where it is discharged over a period of days to the in-situ material underlying the bioretention area or through an underdrain.

It is important to emphasize that whenever possible, bioretention areas should be designed as an off-line treatment system. As shown in the figure, runoff from precipitation provides the major source of the water to be used for bioretention. Water exits the bioretention area by infiltration or evapotranspiration. Excess runoff that cannot be infiltrated or ponded or lost through evapotranspiration is diverted away from the bioretention area. The diversion of excess runoff is accomplished by grading the bioretention area such that the ponded surface elevation is equivalent to the elevation at which runoff is discharging into the bioretention area.

A. Functions of the Bioretention Area Components

The bioretention area components have been combined to have complementary roles or functions to improve water quality. The six major components of the bioretention area are:

- Grass buffer strip,
- Ponding area,
- Planting soil,
- Sand bed,
- Organic layer, and
- Plant material.

Grass Buffer Strip

The grass buffer strip is located between the impervious surface and the bioretention area. It functions to reduce the runoff velocity and filter particulates from the runoff, prior to discharging to the bioretention area.

Sand Bed

The sand bed is located at the bottom of the bioretention area. It provides for drainage and aeration of the planting soil, and augments the ability of the bioretention area to drain the runoff it receives. The sand bed that is shown on the following drawings to be located at the side of the bioretention area where runoff is received is meant to slow the velocity and spread out the runoff over the bioretention area. This vertical sand layer is no longer being required by Prince George's County, and is not required nor encouraged for use in North Carolina. Originally this vertical sand bed was thought to provide aeration for the roots, but with the introduction of an underdrain it also allowed for short-circuiting of the BMP.

Ponding Area

The ponding area over the root zone provides for some surface storage of the storm water runoff, and provides for the evaporation of a portion of the runoff. Settling of the particulates that have not been filtered by the grass buffer or the sand bed occurs in the ponding area.

Organic Layer or Mulch

The organic layer provides a medium for biological growth and decomposition of organic material. The organic or mulch layer on the surface of the soil has several physical and biological functions. The surface layer acts as a filter for pollutants in the runoff and protects the soil, from drying and eroding and simulates the leaf litter in a forest community. The organic or mulch layer provides an environment for microorganisms to degrade petroleum-based solvents and other pollutants.

Planting Soil

The planting soil is the region which provides the source of water and nutrients for the plants to sustain growth. The voids in the soil also provide for stormwater storage. Clay particles that compose a portion of the soil adsorb heavy metals, nutrients, hydrocarbons, and other pollutants.

Plant Material

The role of plant species in the bioretention concept is to use nutrients and other pollutants and to remove water through evapotranspiration. A forest community structure is replicated to avoid monoculture susceptibility to insect and disease infestation and to create a microclimate which is resistant to the stresses to which landscaped areas in urban areas are subjected, including heat and drying winds.

Figure 7, Bioretention Area Conceptual Layout, From Prince George's Co. Design Manual for Use of Bioretention in Stormwater Management, 1993

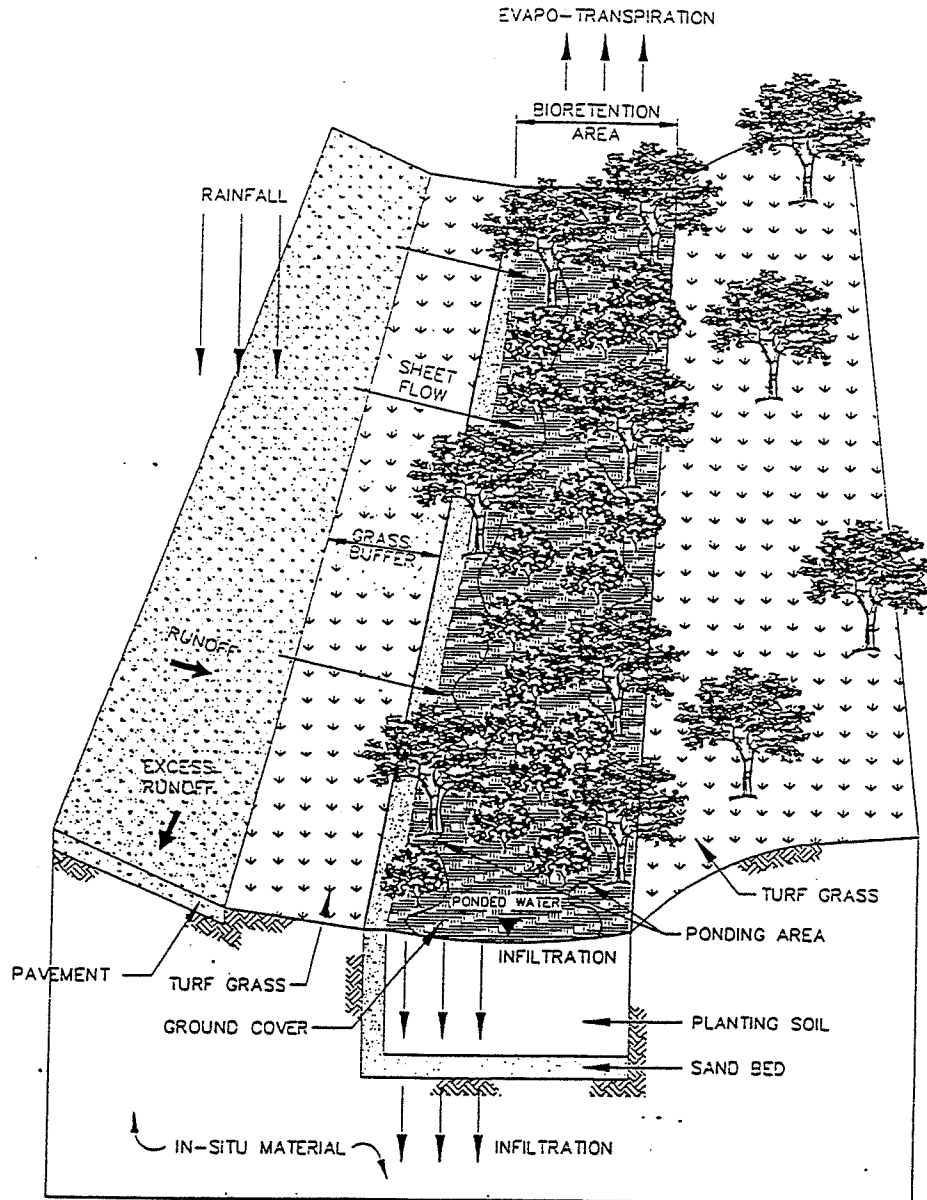

B. Minimum Design Size Requirements

The following dimensions are recommended for bioretention areas regardless of the drainage area size:

- Minimum width of a functional bioretention area should be 15 feet. A width of 25 feet is preferable.
- Minimum length should be 40 feet. For widths equal or greater than 20 feet, the length of the bioretention area should be at least twice the width.
- The ponded area should have a maximum depth of 6 inches.
- The planting soil should have a minimum depth of 4 feet.

The minimum width criterion of 15 feet is especially important in replicating tree and shrub distribution patterns which exist in a forest community. This minimum width will permit the spacing of trees and shrubs in a random fashion that replicates the density and distribution of plants in a natural forest. It also assists in creating a microclimate which can offset the effects of urban stresses resulting from pollutants in stormwater runoff, insect and disease infestation, solar radiation, and wind.

The criterion of designing the length of bioretention area to be twice the width was established for the following reasons: to allow sheet flow to be dispersed over a greater distance, reducing the likelihood of concentrated flow, and to maximize the edge-to-interior area ratio.

The ponding depth of 6 inches was established to provide for adequate surface storage of water so that water would not pond for a period in excess of four days. A ponding time in excess of four days would severely limit the potential plant species for bioretention areas. In addition, a drawdown of water in four days limits the potential of ponded water to breed mosquitoes and other undesirable insects.

The minimum planting soil depth guideline was established based on horticultural and construction considerations. The minimum planting soil depth of four feet was set to provide appropriate moisture capacity, and to create space for the root system of the plants to provide for resistance from windthrow. The construction of the bioretention area requires the excavation of a trench or pit. For most soils, trench depths greater than four feet would require shoring measures.

C. Bioretention Area Types

Conceptual illustrations of various types of bioretention areas are presented in Figures 8 through 11. It should be noted that the layout of the bioretention area will vary according to individual sites, and to specific site constraints such as underlying soils, existing vegetation, drainage, location of utilities, sight distances for traffic, and aesthetics.

The bioretention area featured in Figure 8, to be located adjacent to a parking area without a curb, has the lowest construction cost, since there is no curbing, and the drainage is sheet flow. In a paved area with no curb, pre-cast car stops can be installed along the pavement perimeter to protect the bioretention area.

A bioretention area suitable for traffic areas is shown in Figure 9. The water is diverted into the bioretention area through the use of an inlet deflector block, which has ridges that help channel the runoff into the bioretention area. The gutter, and diversion block should meet the guidelines set forth in the relevant local permitting authority.

A concept for a bioretention traffic island is presented in Figure 10. As shown in the illustration, the minimum recommended width of the traffic island is 20 feet from top of curb to top of curb. When grading a bioretention area in traffic island, a two-foot buffer should be maintained between the curb and the bioretention area. The two foot buffer will minimize the possibility of drainage seeping under the pavement section, and creating "frost heave" during winter months.

A bioretention area suitable for installation along a swale is shown in Figure 11. A berm 1 foot in height separates the swale from the bioretention area. To maintain an off-line system, the bioretention area should be graded such that the overflow from the bioretention area discharges into the swale. It is recommended that the bioretention area invert be a maximum of one-half foot below the swale invert to provide for the appropriate depth of ponded water.

Figure 8. Parking Edge and Perimeter Without Curb, From Prince George's Co. 1993.

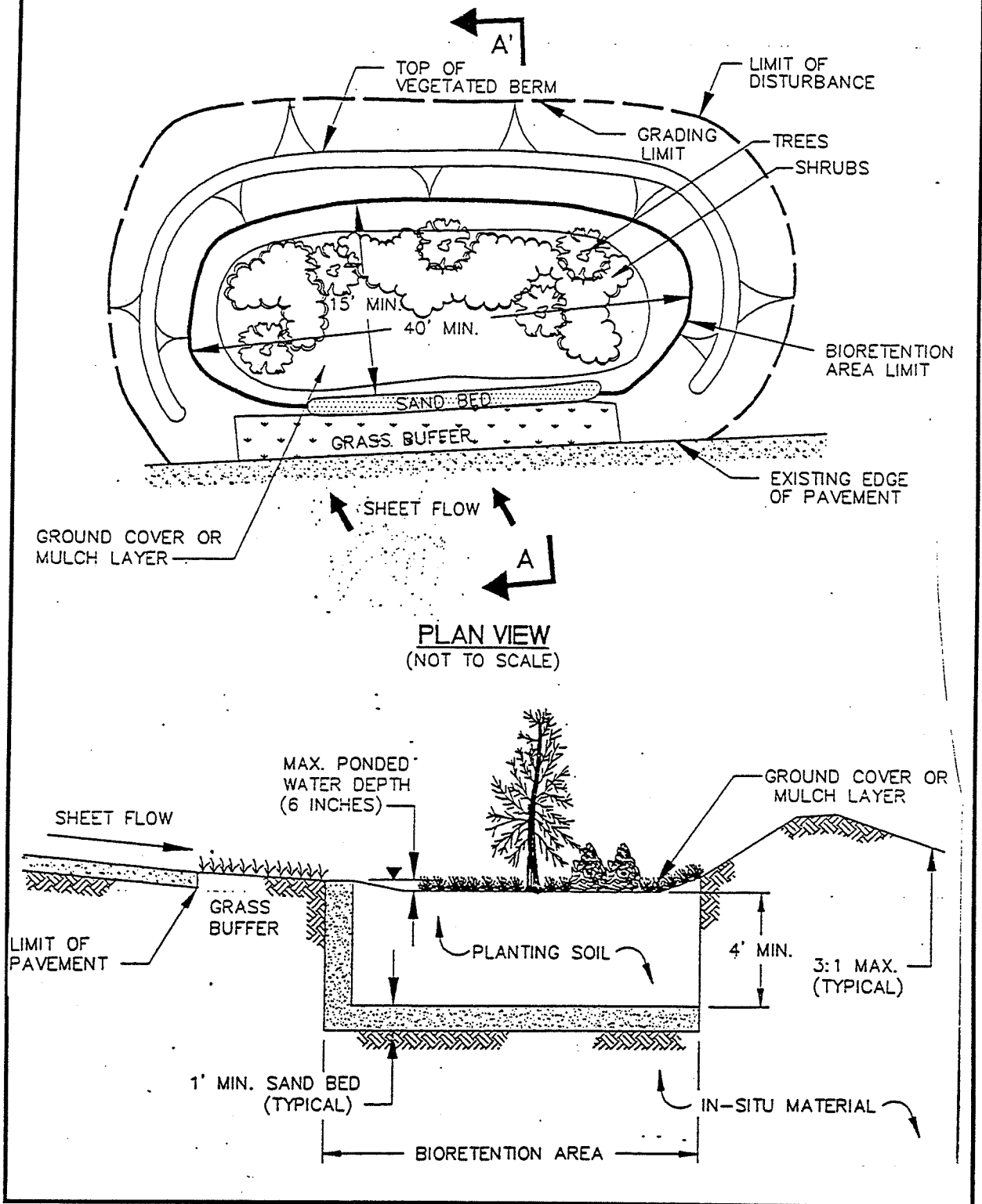
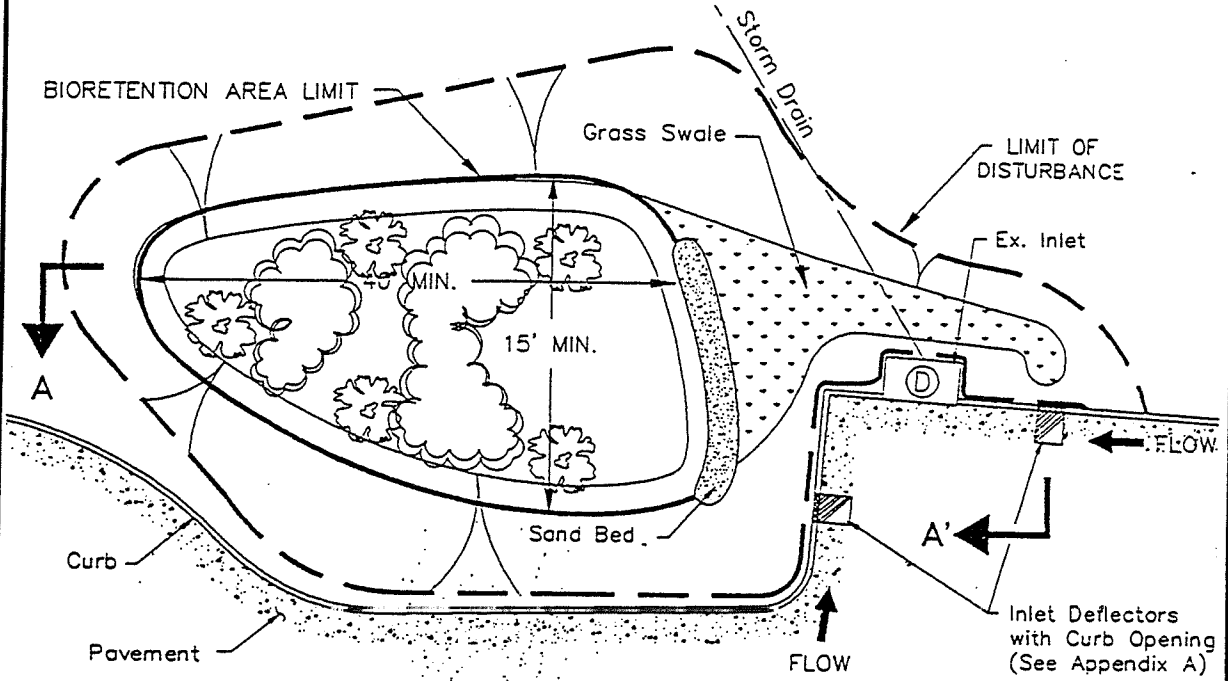
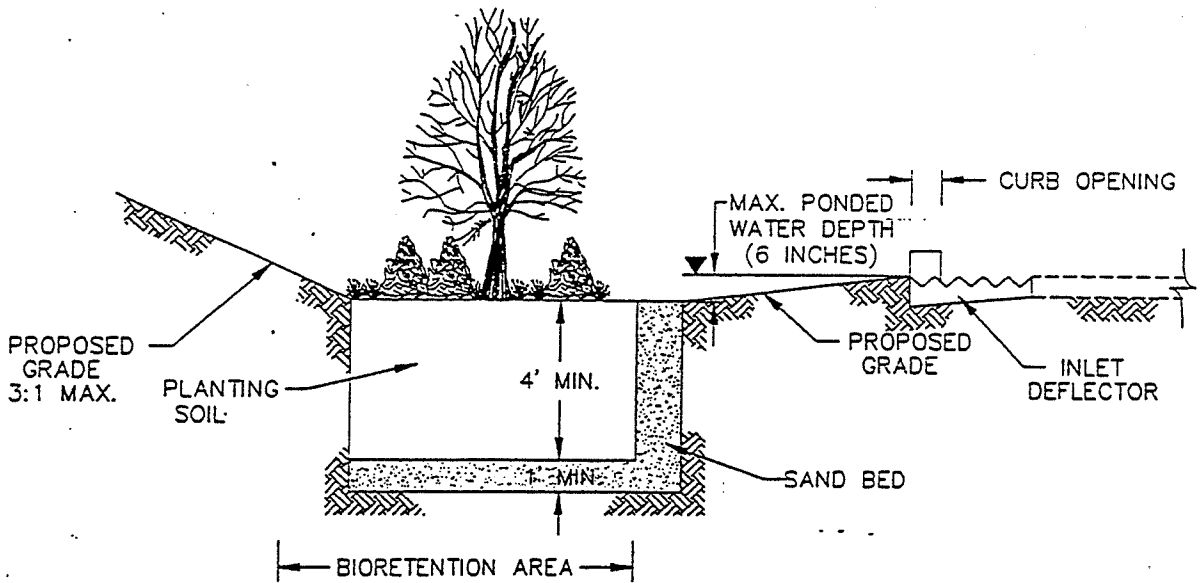

Figure 9. Parking Edge and Perimeter With Curb, From Prince George's Co. 1993



PLAN VIEW
(NOT TO SCALE)



SECTION A-A'
(NOT TO SCALE)

Figure 10. Traffic Island Bioretention Area, From Prince George's Co. 1993

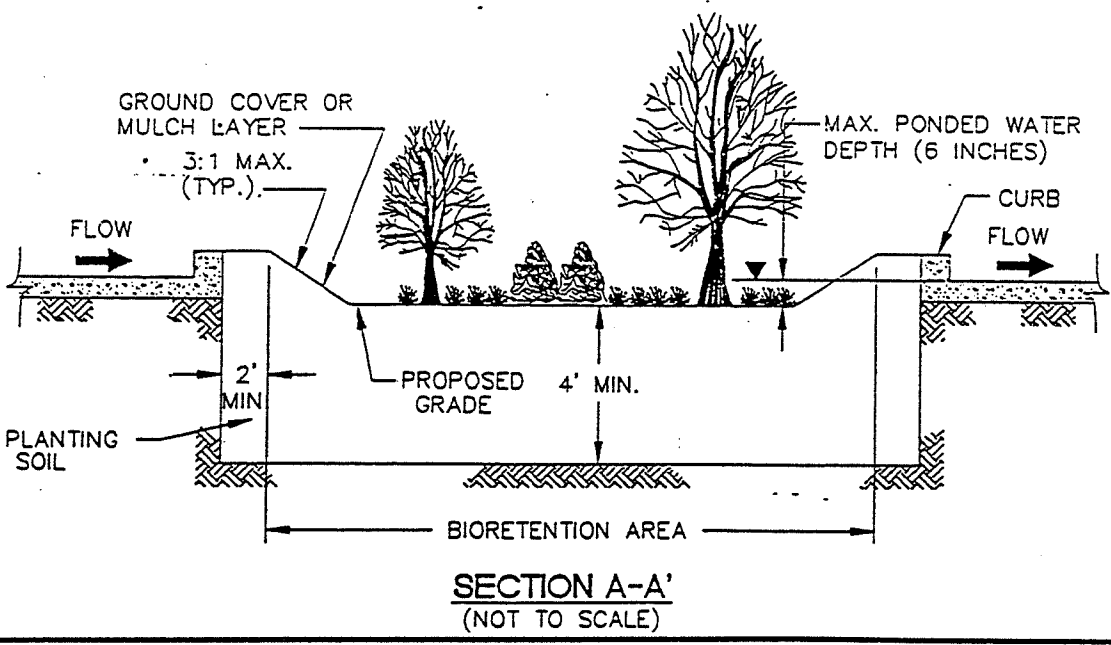
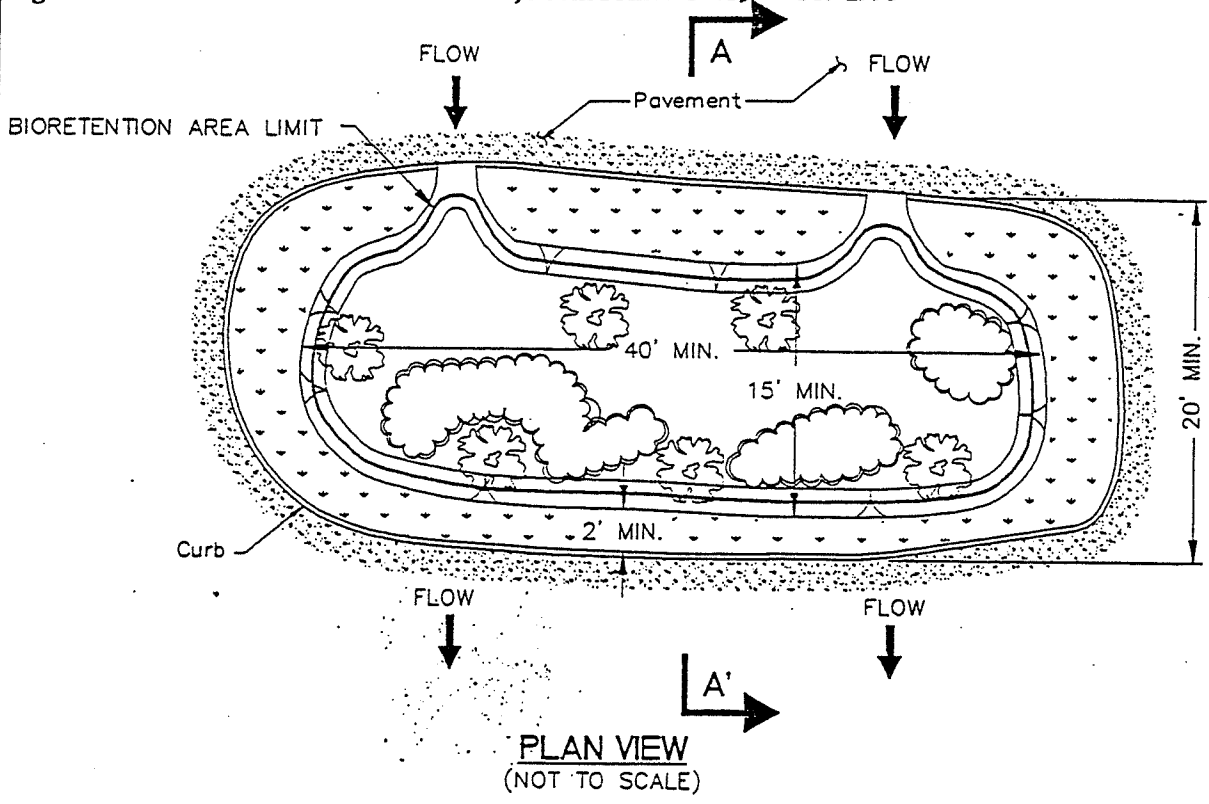
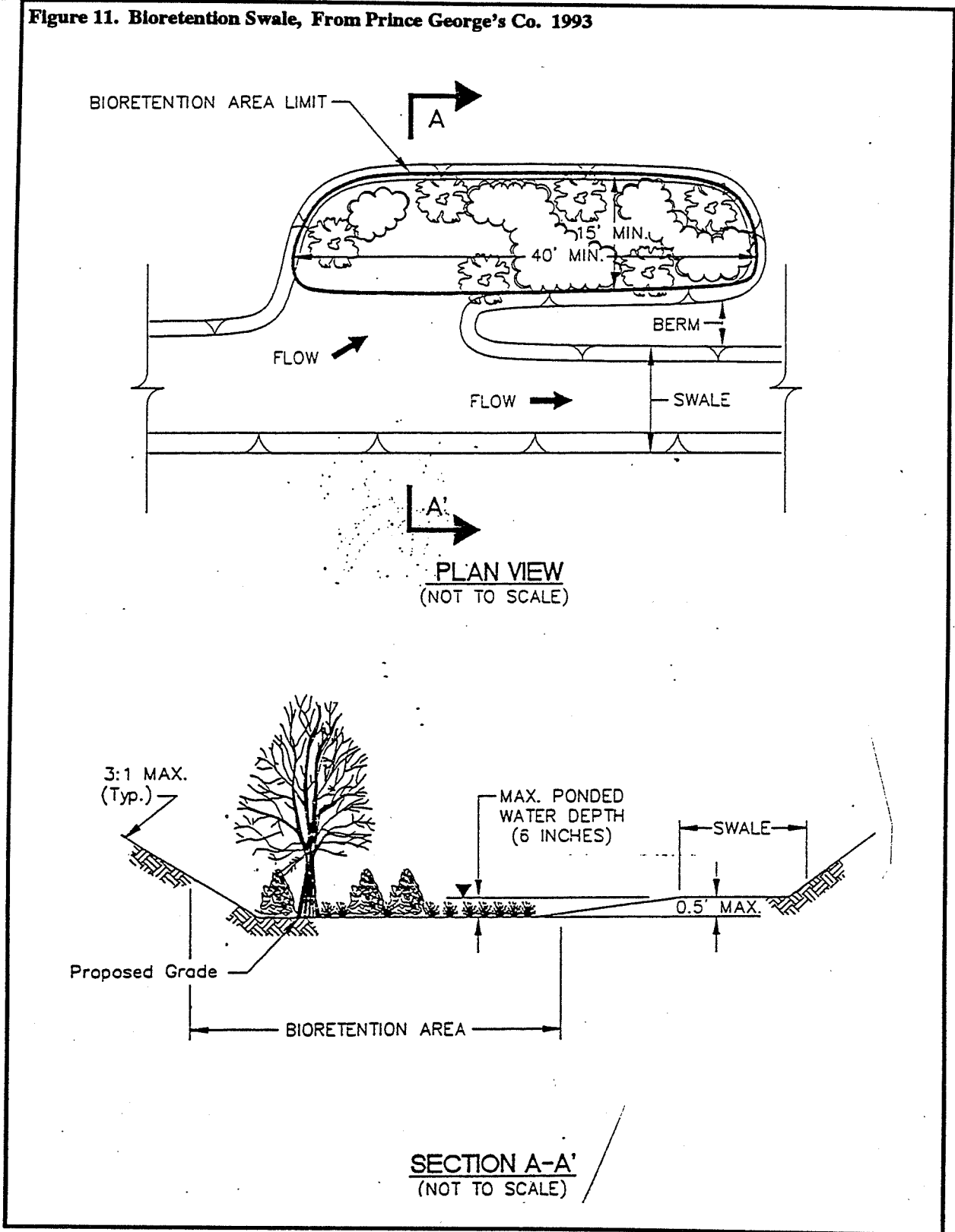

Figure 11. Bioretention Swale, From Prince George's Co. 1993



III. Grading Plan

A. Locating the Bioretention Area

1. Stormwater Management Concept Plan

The first step in locating a bioretention area for a site is creating a stormwater management concept plan. The purpose of the stormwater concept plan is to ensure the implementation of proper site management quality control practices during the early planning stages of the site development process. The information needed to develop the concept plan includes: existing and proposed drainage areas, soils, vegetation, and hydrographic features such as streams, floodplains, and wetlands.

In North Carolina, bioretention areas will be limited to drainage areas less than 5 acres in size. However, in many cases the application of bioretention areas will be limited because of erosive velocities to 0.25 to 1 acre. The limiting factor in the drainage area size is the amount of sheet flow runoff for the 10-year storm. Generally, commercial, industrial, or residential drainage areas exceeding 1 acre in size will have sheet flow greater than the 5 cfs. When sheet flow exceeds this level, the designer should investigate the potential erosion to vegetated areas.

2. Location Guidelines

Preferable locations for bioretention areas include:

- areas upland from inlets or outfalls that receive sheet flow from graded areas, and
- areas of the site that will be excavated or cut.

The following locations would be undesirable for bioretention:

- areas that have a water table within 6 feet of the land surface,
- areas that have mature trees which would be removed for construction of the bioretention area,
- areas that have existing slopes of 20% or greater, and
- areas in close proximity to an unstable soil stratum.

When available, areas of loamy sand soils should be used for siting the bioretention areas. These soft types comprise the planting soils for bioretention areas, and locating bioretention areas in these soils would eliminate the cost of importation of planting soil. (See soil and organic specifications in Section V.)

B. Sizing Guidelines

The first step in developing the grading plan is determining the size of the bioretention area. The drainage area contributing to each bioretention area should be delineated for the site. The Rational Method "c" coefficient should then be determined for the drainage area using the methodology described in the North Carolina Erosion and Sediment Control Manual, Appendix 8.03.

The size of the bioretention area should be 5% to 7% of the drainage area multiplied by the Rational "c" coefficient. If the bioretention area is constructed according to the concept, that is, including a sand bed, then the size of the bioretention area should be 5% of the drainage area multiplied by the Rational "c" coefficient. If the use of a sand is not considered appropriate at a particular site, then the size of the bioretention area should be 7% of the drainage area multiplied by the Rational "c" coefficient.

The sizing rule is based on the bioretention area infiltrating precipitation events of 0.5 to 0.7 inches occurring over a six-hour time period. The precipitation amount and duration corresponds to the median storm event for most of North Carolina (USEPA, 1986). A description of the methodology used to determine the amount of runoff infiltrated into the bioretention area is contained in Section VIII., Water Balance Computations.

A sample computation of the size of a bioretention area is presented in Figure 12. The figure includes a map of the drainage area that would drain to the sample bioretention area.

Figure 12. Sizing of a Bioretention Area, From Prince George's Co, 1993

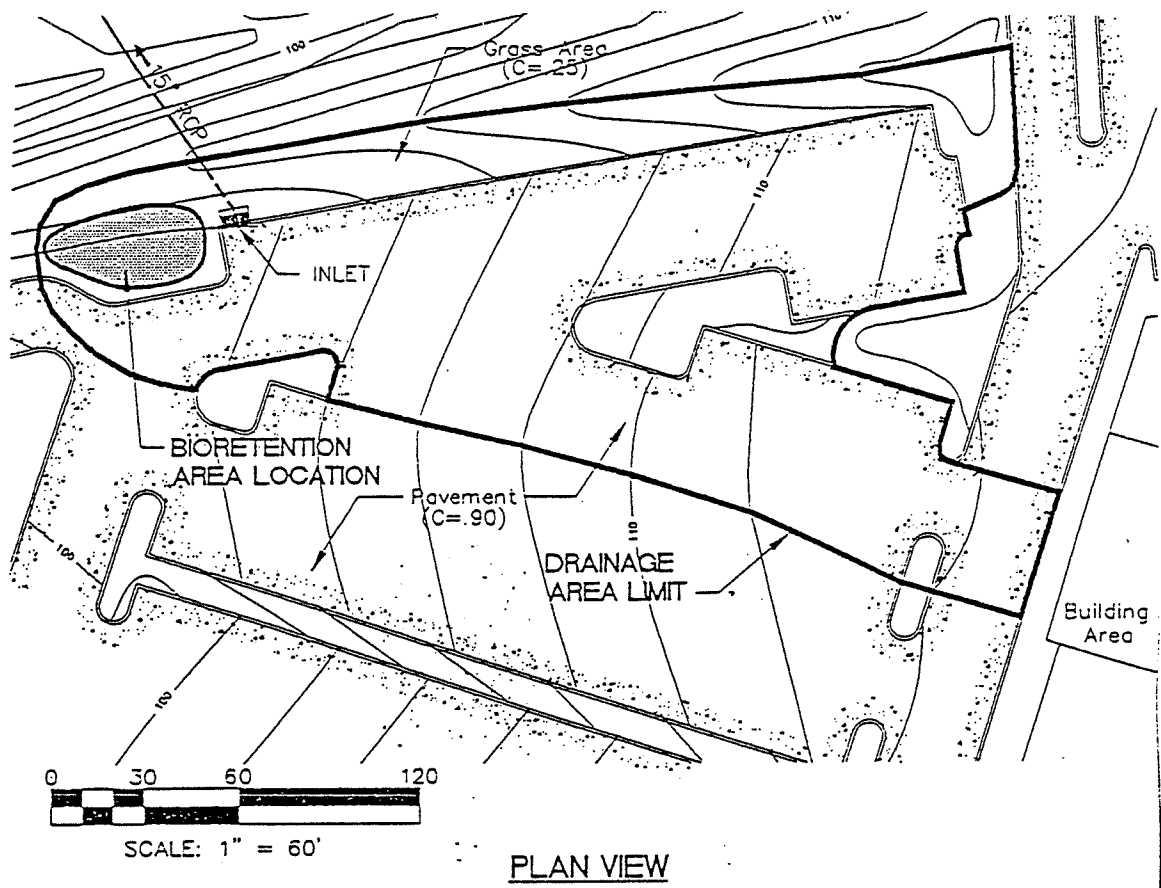

BIORETENTION AREA
SIZING COMPUTATION

<u>DEVELOPMENT</u>	<u>AREA (SQ. FT.)</u>	<u>"C" * FACTOR</u>	<u>C x AREA</u>
PAVEMENT	23,800	0.90	21,400
GRASS	10,100	0.25	2,500
TOTALS	33,000		23,900

BIORETENTION AREA SIZE

1. WITH SAND BED (5% SUM OF C x AREA)
= .05 x 23,900 = 1,195 OR SAY 1,200 SQ. FT.
2. WITHOUT SAND BED (7% SUM OF C x AREA)
= .07 x 23,900 = 1,673 OR SAY 1,700 SQ. FT.

*SEE CHAPTER IV, PRINCE GEORGES COUNTY STORMWATER MANAGEMENT MANUAL

C. Drainage Considerations

The runoff entering the bioretention areas will be in the form of sheet flow. There are two major drainage considerations in the design of bioretention areas:

- the diversion of the "first flush" of runoff into the bioretention area, and
- the potential erosion of the surface of the bioretention area by the sheet flow.

The diversion of the "first flush" can be accomplished by having sheet flow drain directly into the bioretention area as shown in Figure 8, or through curb openings as shown in Figure 9. The curb openings should have a width of 3 feet, which allows for the first one inch of runoff to be intercepted, but diverts larger flows around the bioretention area, maintaining an off-line system. The hydraulic analysis was developed using HEC-12, Drainage of Highway Pavements (U.S. D.O.T., 1984) using a drainage area of one acre and having a commercial land use (runoff coefficient of 0.8). The hydraulic capacity is also based on a diversion block in front of the curb opening. Multiple curb openings should be considered for longitudinal slopes greater than 7%.

The potential erosion created by the sheet flow is a major concern in the design of the bioretention areas. Planted ground cover can withstand a higher sheet flow velocity than mulch. It is recommended that the maximum inflow sheet flow velocity for planted ground cover be 3 feet per second, and the maximum inflow velocity for mulched areas be less than 1 ft/sec. Hydraulic analysis indicates that the outflow velocity from a 3-foot curb cut draining a 1-acre commercial tract is 0.5 ft/sec, and would be non-erosive to either type of cover.

Where bioretention areas drain sheet flow from asphalt pavement, velocities can exceed 3 ft/sec for:

- 100-foot lengths of asphalt pavement of slope exceeding 20%.
- 200-foot lengths of asphalt pavement of slope exceeding 5%.

The sheet flow computations reflect laminar flow conditions. Flow in a paved or graded area varies with the incongruities found in the surface, and will have a tendency to concentrate in the depressions. The velocity of the concentrated flow would be higher than the laminar sheet flow velocity, and may have the potential to erode the vegetation.

D. Grading Plan Guidelines

The goal of the grading scheme is for the first flush of runoff to be diverted into the bioretention areas, and for larger flows to drain to the existing storm sewer system. The bypass of the larger storm volumes allows for the retention of the first flush of runoff which has the highest concentration of pollutants. A sample grading plan and elevation detail for a bioretention area is shown in Figure 13. The grading plan was created for a double-cell bioretention area. There is a seven-foot buffer between cells which allow for the planting of upland trees. As indicated in the grading plan, sheet and gutter flow is diverted into the bioretention areas through openings in the curb. Inlet deflector blocks are located in front of the curb openings to channel the flow into the bioretention area. The elevation of the invert of the bioretention area is set by the curb opening elevation. The curb opening elevation is 0.5 ft. higher than the invert of the bioretention area, so water is allowed to pond to a maximum depth of one-half foot before runoff bypasses the bioretention area and flows into the storm drain system.

Figure 13. Sample Grading Plan, From Prince George's Co. 1993

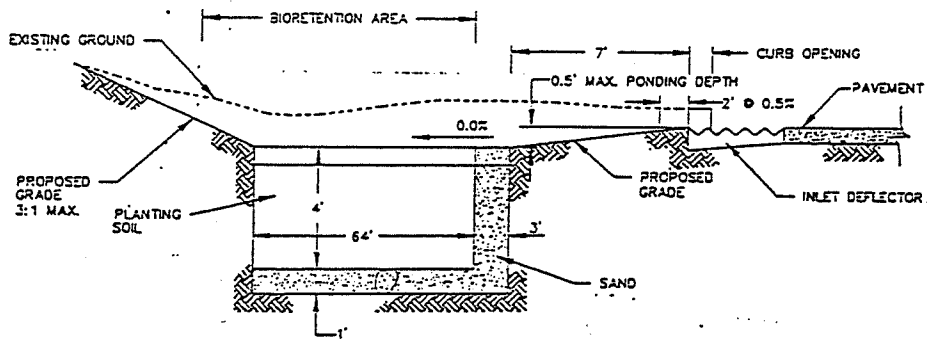
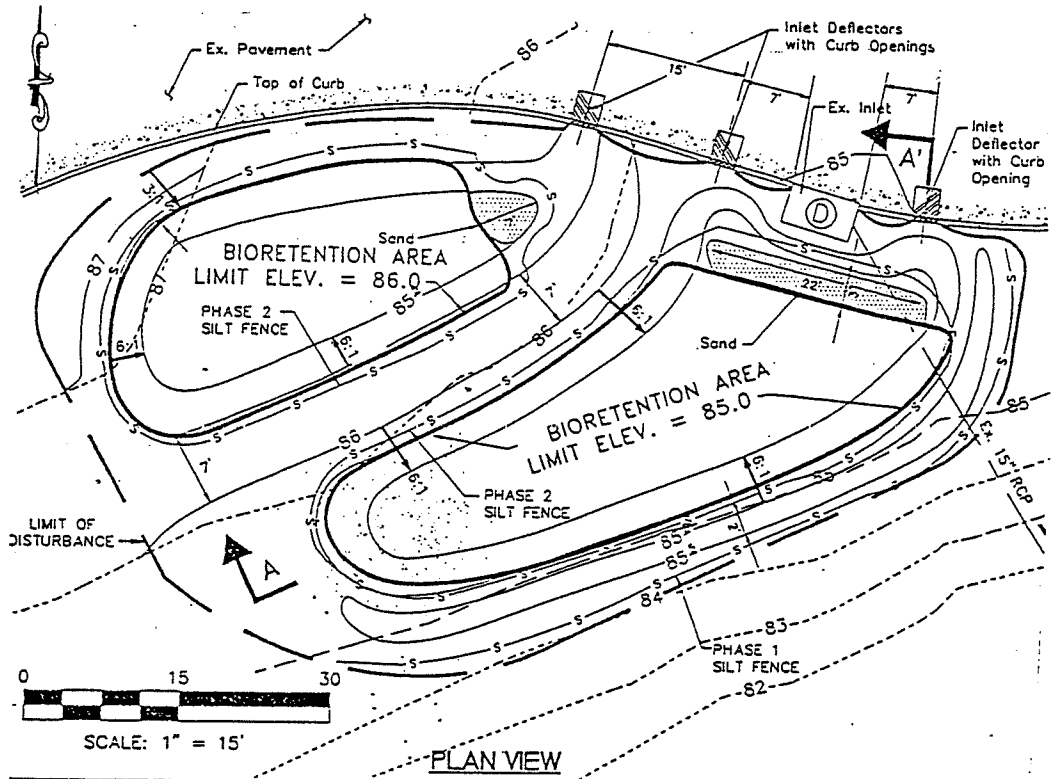

SECTION A-A'
(NOT TO SCALE)

Where space constraints allow, runoff to the bioretention areas should be filtered by a grass buffer strip and sand bed, as shown in Figure 7. The buffer strip and the sand bed will reduce the amount of fine material entering the bioretention area, and minimize the potential for clogging of the planting soil. The sand bed also increases the infiltration capacity and acts as a level spreader to evenly distribute flow within the bioretention area .

It is necessary to sequence the installation of sediment and erosion controls to minimize the contamination of the planting soil with silts and fines. Sediment controls are installed around the area to be disturbed before grading, and around the bioretention area before the excavation of the trench or pit for the planting soil. Sands and fines will have a tendency to clog the planting soil, and impair the functions of the bioretention area.

IV. Planting Plan

The planting plan considerations include site planning and aesthetic considerations for designing the bioretention plant community. Tables listing suitable species of trees, shrubs, and ground cover are provided at the end of this section.

A. Planting Plan Concept

The use of plant material in bioretention areas is modeled from the properties of a terrestrial forest community ecosystem. The terrestrial forest community ecosystem is an upland community dominated by trees, typically with a mature canopy, having a distinct sub-canopy of understory trees, a shrub layer, and herbaceous layer. In addition, the terrestrial forest ecosystem typically has a well-developed soil horizon with an organic layer and a mesic moisture regime. A terrestrial forest community model for stormwater management was selected based upon a forest's documented ability to cycle and assimilate: nutrients, pollutants, and metals through the interactions among plants, soil, and the organic layer.

Key elements of the terrestrial forest ecosystem that have been incorporated into bioretention design include species diversity, density, and morphology, and use of native plant species. Species diversity protects the system against collapse from insect and disease infestations and other urban stresses such as temperature and exposure. Typically, native plants demonstrate a greater ability of adapting and tolerating physical, climatic, and biological stresses (Metropolitan Washington Council of Governments, 1992).

B. Plant Species Selection

Plant species appropriate for use in bioretention areas are presented in Table IV.1, provided at the end of this section. These species have been selected based on their ability to tolerate urban stresses such as pollutants, variable soil moisture and ponding fluctuations. Important design considerations such as form, size, and type of root system are also included. A key factor in determining the suitability of a species is its ability to tolerate the soil moisture regime and ponding fluctuations associated with bioretention. The plant indicator status (Reed, 1988) of listed species are predominantly facultative (i.e., they are adapted to stresses associated with both wet and dry conditions); however, facultative upland and wetland species have also been included. This is important because plants in bioretention areas will be exposed to varying levels of soil moisture and ponding throughout the year, ranging from high levels in the spring to potential drought conditions in the summer. All of the species listed in Table IV. 1 are commonly found growing in the Piedmont or Coastal Plain regions of North Carolina as either native or ornamental species.

Designers considering species other than ones listed in Table IV.2 should consult the following reference material on plant habitat requirements, and consider site conditions to ensure that alternative plant material will survive:

- Hightshoe, G.L., 1988. *Native Trees, Shrubs and Vines for Urban and Rural America*. Van Nostrand Reinhold, New York, New York.
- Reed, P.B.Jr., 1988. *National List of Species That Occur in Wetlands: Northeast*. United States Fish and Wildlife Service, St. Petersburg, Florida.

Reasons for exclusion of certain plants from bioretention areas include inability to meet the criteria outlined in Table IV.2 (pollutant and metals tolerance, soil moisture and ponding fluctuations, morphology, etc.) In addition, species that are considered invasive, or otherwise not recommended, should not be specified.

C. Site and Ecological Considerations

Each site is unique and may contain factors that should be considered before selecting plant species. An example plant material checklist is provided in Section X. The checklist has been developed to assist the designer in identifying critical factors about a site that may affect both the plant material layout and the species selection.

Selection of plant species should be based on site conditions and ecological factors. Site considerations include microclimate (light, temperature, wind), the importance of aesthetics, overall site development layout, and the extent of maintenance requirements. Exposure to wind and light will affect the candidate species. These factors combined with the potential sitings of any structures will also need to be considered. Of particular concern is the increase in reflection of solar radiation from buildings upon bioretention areas. Aesthetics can be important in development projects that have high visibility. Species that require regular maintenance (shed fruit or are prone to storm damage) should be restricted to limited visibility and pedestrian and vehicular traffic.

Species selection should consider interactions with adjacent plant communities. Nearby existing vegetated areas dominated by non-native invasive species pose a threat to adjacent bioretention areas. Adjacent plant communities should be evaluated for compatibility with any proposed bioretention area species. Invasive species typically develop into monocultures by out competing other species. Mechanisms to avoid encroachment of undesirable species include providing a soil breach between the invasive community for those species that spread through rhizomes and providing annual removal of seedlings from wind borne seed dispersal. It is equally important to determine if there are existing disease or insect infestation associated with existing species on site or in the general area that may effect the bioretention plantings.

D. Number of Species

A minimum of three species of trees and three species of shrubs should be selected to insure diversity. In addition to reducing the potential for monoculture mortality concerns, a diversity of trees and shrubs with differing rates of transpiration may ensure a more constant rate of evapotranspiration and nutrient and pollutant uptake throughout the growing season.

Herbaceous ground covers are important to prevent erosion of the mulch and the soil layers. Suitable herbaceous ground covers are identified in Table IV.3

Species	Moisture Regime				Tolerance										Morphology			General Characteristics	
	Indicator Status	Habitat	Ponding	Salt	Oil/Grease	Metal	Insects	Exposure	Form	Height	Root System	Native	Wildlife	Form	Height	Root System	Native	Wildlife	
<i>Berberis koreana</i> barberry	FAC	Mesic	2-4	H	H	H	M	Sun to partial Shade	Oval shrub	4-6'	Shallow	No	Low						
<i>Berberis thunbergii</i> Japanese barberry	FAC	Mesic	2-4	H	H	M	M	Sun	Rounded, dense shrub	5-7'	Shallow	No	Med.						
<i>Clethra alnifolia</i> sweet pepperbush	FAC	Mesic to wet mesic	2-4	H	-	-	H	Sun to partial Shade	Ovoid shrub	6-12'	Shallow	Yes	Med.						
<i>Cornus Stolonifera</i> red osler dogwood	FACW	Mesic - Hydric	2-4	H	H	H	M	Sun or Shade	Arching, Spreading	8-10'	Shallow	Yes	High						
<i>Euonymus alatus</i> winged euonymus	FAC	Mesic	1-2	H	H	H	M	Sun or shade	Flat, dense, horizontal branching	5-7'	Shallow	No	No						
<i>Euonymus europaeus</i> spindle-tree	FAC	Mesic	1-2	M	M	M	M	Sun to partial shade	Up-right dense oval shrub	10-12'	Shallow	No	No						
<i>Hamamelis virginica</i> witch-hazel	FAC	Mesic	2-4	M	M	M	M	Sun or Shade	Vase-like compact shrub	4-6'	Shallow	Yes	Low						
<i>Hypericum densiflorum</i> common St. John's wort	FAC	Mesic	2-4	H	M	M	H	Sun	Ovoid Shrub	3-6'	Shallow	Yes	Med						
<i>Ilex glabra</i> inkberry	FACW	Mesic to wet Mesic	2-4	L	M	-	H	Sun to partial sun	Spreading shrub	6-12'	Shallow	Yes	High						
<i>Ilex verticillata</i> winterberry	FACW	Mesic to wet Mesic	2-4	L	M	-	H	Sun to partial sun	Spreading shrub	6-12'	Shallow	Yes	High						
<i>Juniperus communis</i> "comressa" common juniper	FAC	Dry Mesic to Mesic	1-2	M	H	H	M-H	Sun	Mounded shrub	3-6'	Deep taproot	No	High						
<i>Juniperus horizontalis</i> "Bar Harbor" creeping juniper	FAC	Dry Mesic to Mesic	1-2	M	H	H	M-H	Sun	Matted shrub	0-3'	Deep taproot	No	High						
<i>Lindera benzoin</i> spicebush	FACW	Mesic to wet Mesic	2-4	H	-	-	H	Sun	Upright shrub	6-12'	Deep	Yes	High						
<i>Myrica pennsylvanica</i>	FAC	Mesic	2-4	H	M	M	H	Sun to partial	Rounded,	6-8'	Shallow	Yes	High						

FAC = Facultative - Equally likely to occur in wetlands or non-wetlands
 FACU = Facultative Upland - Usually occur in non-wetlands, but occasionally found in wetlands
 FACW = Facultative Wetland - Usually occur in wetlands, but occasionally found in non-wetlands

bayberry									sun	compacted shrub				
<i>Physocarpus opulifolius</i> ninebark	FAC	Dry Mesic to wet Mesic	2-4	M	-	H	H	H	Sun	Upright shrub	6-12'	Shallow	Yes	Med
<i>Viburnum cassinoides</i> northern wild raisin	FACW	Mesic	2-4	H	H	H	H	H	Sun to partial sun	Rounded, compacted shrub	6-8'	Shallow	Yes	High
<i>Viburnum dentatum</i> arrow-wood	FAC	Mesic	2-4	H	H	H	H	H	Sun to partial sun	Upright, multi-stemmed shrub	8-10'	Shallow	Yes	High
<i>Viburnum lentago</i> nannyberry	FAC	Mesic	2-4	H	H	H	H	H	Sun to partial sun	Upright, multi-stemmed shrub	8-10'	Shallow	Yes	High

FAC = Facultative - Equally likely to occur in wetlands or non-wetlands
FACU = Facultative Upland - Usually occur in non-wetlands, but occasionally found in wetlands
FACW = Facultative Wetland - Usually occur in wetlands, but occasionally found in non-wetlands

Table IV.2 RECOMMENDED PLANT SPECIES FOR USE IN BIORETENTION --- TREE SPECIES

Species	Tolerance										Morphology			General Characteristics									
	Moisture Regime		Grease		Salt		Oil/Grease		Metals		Insects		Exposure		Form		Height		Root System		Native		Wildlife
Scientific Name Common Name	Indicator Status	Habitat	Ponding	Salt	Oil/Grease	Metals	Insects	Exposure	Form	Height	Root System	Native	Wildlife										
<i>Acer rubrum</i> red maple	FAC	Mesic - Hydric	4-6	H	H	H	H	Partial Sun	Single to multi-stem tree	50-70'	Shallow	Yes	High										
<i>Amelanchier canadensis</i> shadbush	FAC	Mesic	2-4	H	M	-	H	Partial Sun	Single to multi-stem tree	30-50'	Shallow	Yes	High										
<i>Betula nigra</i> river birch	FACW	Mesic to Hydric	4-6	-	M	M	H	Partial Sun	Single to multi-stem tree	50-75'	Shallow	Yes	Med.										
<i>Betula populifolia</i> gray birch	FAC	Xeric-Hydric	4-6	H	H	M	H	Partial Sun	Single to multi-stem tree	35-50'	Shallow to deep	Yes	High										
<i>Fraxinus americana</i> white ash	FAC	Mesic	2-4	M	H	H	H	Sun	Large tree	50-80'	Deep	Yes	Low										
<i>Fraxinus pennsylvanica</i> green ash	FACW	Mesic	4-6	M	H	H	H	Partial Sun	Large tree	40-65'	Shallow to deep	Yes	Low										
<i>Ginkgo biloba</i> Maidenhair tree	FAC	Mesic	2-4	H	H	H	H	Sun	Large tree	50-80'	Shallow to deep	No	Low										
<i>Gleditsia triacanthos</i> honeylocust	FAC	Mesic	2-4	H	M	-	M	Sun	Small canopied large tree	50-75'	Shallow to deep taproot	Yes	Low										
<i>Juniperus virginiana</i> eastern red cedar	FACU	Mesic - Xeric	2-4	H	H	-	H	Sun	Dense single stem tree	50-75'	Taproot	Yes	Very High										
<i>Koeleruteria paniculate</i> golden-rain tree	FACU	Mesic	2-4	H	H	H	H	Sun	Round, dense shade tree	20-30'	Shallow	No	No										
<i>Liquidambar styraciflua</i> sweet gum	FAC	Mesic	4-6	H	H	H	M	Sun	Large tree	50-70'	Deep taproot	Yes	High										
<i>Nyssa sylvatica</i> black gum	FACW	Mesic - Hydric	4-6	H	H	H	H	Sun	Large tree	40-70'	Shallow to deep taproot	Yes	High										
<i>Platanus acerfolia</i> London plane-tree	FACW	Mesic	2-4	H	-	-	M	Sun	Large tree	70-80'	Shallow	No	Low										
<i>Platanus occidentalis</i> sycamore	FACW	Mesic - Hydric	4-6	M	M	M	M	Sun	Large tree	70-80'	Shallow	Yes	Med.										

FAC = Facultative - Equally likely to occur in wetlands or non-wetlands
 FACU = Facultative Upland - Usually occur in non-wetlands, but occasionally found in wetlands
 FACW = Facultative Wetland - Usually occur in wetlands, but occasionally found in non-wetlands

<i>Populus deltoides</i> eastern cottonwood	FAC	Xeric - Mesic	4-6	H	H	H	H	L	Sun	Large tree with spreading branches	75- 100'	Shallow	Yes	High
<i>Pyrus calleryana</i> Callery pear	FAC	Mesic	2-4	H	H	H	H	H	Sun	Dense shade tree	30-50'	Shallow to deep	No	Low
<i>Quercus bicolor</i> swamp white oak	FACW	Mesic to wet Mesic	4-6	H	-	H	H	H	Sun to partial sun	Large tree	75- 100'	Shallow	Yes	High
<i>Quercus coccinea</i> scarlet oak	FAC	Mesic	1-2	H	M	M	M	M	Sun	Large tree	50-75'	Shallow to deep	Yes	High
<i>Quercus macrocarpa</i> bur oak	FAC	Mesic to wet Mesic	2-4	H	H	H	H	M	Sun	Large spreading tree	75- 100'	Taproot	No	High
<i>Quercus palustris</i> Pin oak	FACW	Mesic- Hydric	4-6	H	H	H	H	M	Sun	Large tree	60-80'	Shallow to deep taproot	Yes	High
<i>Quercus phellos</i> willow oak	FACW	Mesic to wet Mesic	4-6	H	-	-	-	H	Sun	Large tree	55-75'	Shallow	Yes	High
<i>Quercus rubra</i>	FAC	Mesic	2-4	M	H	M	M	M	Sun to partial sun	Large spreading tree	60-80'	Deep taproot	Yes	High

FAC = Facultative - Equally likely to occur in wetlands or non-wetlands
FACU = Facultative Upland - Usually occur in non-wetlands, but occasionally found in wetlands
FACW = Facultative Wetland - Usually occur in wetlands, but occasionally found in non-wetlands

Table IV.3 RECOMMENDED PLANT SPECIES FOR USE IN BIORETENTION --- Herbaceous Ground Cover															
Species	Moisture Regime				Tolerance				Morphology					General Characteristics	
	Indicator Status	Habitat	Ponding	Salt	Oil/Grease	Metals	Insects	Exposure	Form	Height	Root System	Native	Wildlife		
<i>Agrostis alba</i> redtop	FAC	Mesic - Xeric	1-2	H	-	H	H	Shade	Grass	2-3'	Fibrous Shallow	Yes	High		
<i>Andropogon gerardi</i> bluejoint	FAC	Dry Mesic - Mesic	1-2	-	-	-	-	Sun	Grass	2-3'	Fibrous Shallow	Yes	High		
<i>Deschampsia caespitosa</i> tufted hairgrass	FACW	Mesic to wet Mesic	2-4	H	-	H	H	Sun	Grass	2-3'	Fibrous Shallow	Yes	Med.		
<i>Hedera Helix</i> English Ivy	FACU	Mesic	1-2	-	-	-	H	Sun	Evergreen ground cover	-	Fibrous Shallow	No	Low		
<i>Lotus Corniculatus</i> birdsfoot-trefoil	FAC	Mesic - Xeric	1-2	H	L	H	H	Sun	Grass	2-3'	Fibrous Shallow	Yes	High		
<i>Pachysandra terminalis</i> Japanese pachysandria	FACU	Mesic	1-2	-	-	-	M	Shade	Evergreen ground cover	-	Fibrous Shallow	No	Low		
<i>Panicum veratum</i> switch grass	FAC to FACU	Mesic	2-4	H	-	-	H	Sun or Shade	Grass	4-5'	Fibrous Shallow	Yes	High		
<i>Parthenocissus</i> Boston Ivy	FACU	Mesic	1-2	-	-	-	H	Shade	Evergreen ground cover	-	Fibrous Shallow	No	Low		
<i>Vinca major</i> large periwinkle	FACU	Mesic	1-2	-	-	-	H	Shade	Evergreen ground cover	-	Fibrous Shallow	No	Low		
<i>Vinca minor</i> common periwinkle	FACU	Mesic	1-2	-	-	-	H	Shade	Evergreen ground cover	-	Fibrous Shallow	No	Low		

FAC = Facultative - Equally likely to occur in wetlands or non-wetlands
FACU = Facultative Upland - Usually occur in non-wetlands, but occasionally found in wetlands
FACW = Facultative Wetland - Usually occur in wetlands, but occasionally found in non-wetlands

E. Number and Size of Plants

The number of tree and shrub plantings may vary, especially in areas where aesthetics and visibility are vital to site development, and should be determined on an individual site basis. On average, 1000 trees and shrubs should be planted per acre. For example, a bioretention area measuring 15' x 40' would contain a combination of trees and shrubs totaling 14 individuals. The recommended minimum and maximum number of individuals and spacing are given in Table IV.4

Two to three shrubs should be specified for each tree (2:1 to 3:1 ratio of shrubs to trees).

Table IV.4 Recommended Tree and Shrub Spacing	Tree Spacing (feet)	Shrub Spacing (feet)	Total Density (stems/acre)
Maximum	19	12	400
Average	12	8	1000
Minimum	11	7	1250

At installation, trees should be 2.5 inches in caliper, and shrubs 3 to 4 feet in height or 18 to 24 inches in spread. Ground cover may be as seed or, preferably, plugs. The relatively mature size requirements for trees and shrubs are important to ensure that the installation of plants are readily contributing to the bioretention process (i.e., evapotranspiration, pollutant uptake).

F. Plant Material Layout

The layout of plant material can be a flexible process; however, the designer should follow some basic guidelines. As discussed above, the designer should first review the Plant Checklist, Section X. The checklist table can help expose any constraints that may limit the use of a particular species and/or where a species can be installed.

There are two guidelines that should apply to all bioretention areas. First, woody plant material should not be placed within the immediate areas of where flow will be entering the bioretention area. Besides possibly concentrating flows, trees and shrubs can be damaged as a result of the flow. Secondly, it is recommended that trees be planted primarily on the perimeter of bioretention areas, to maximize the shading and sheltering of bioretention areas and to create a microclimate which will limit the extreme exposure from summer solar radiation and winter freezes and winds. An example planting plan is shown in Figure 14.



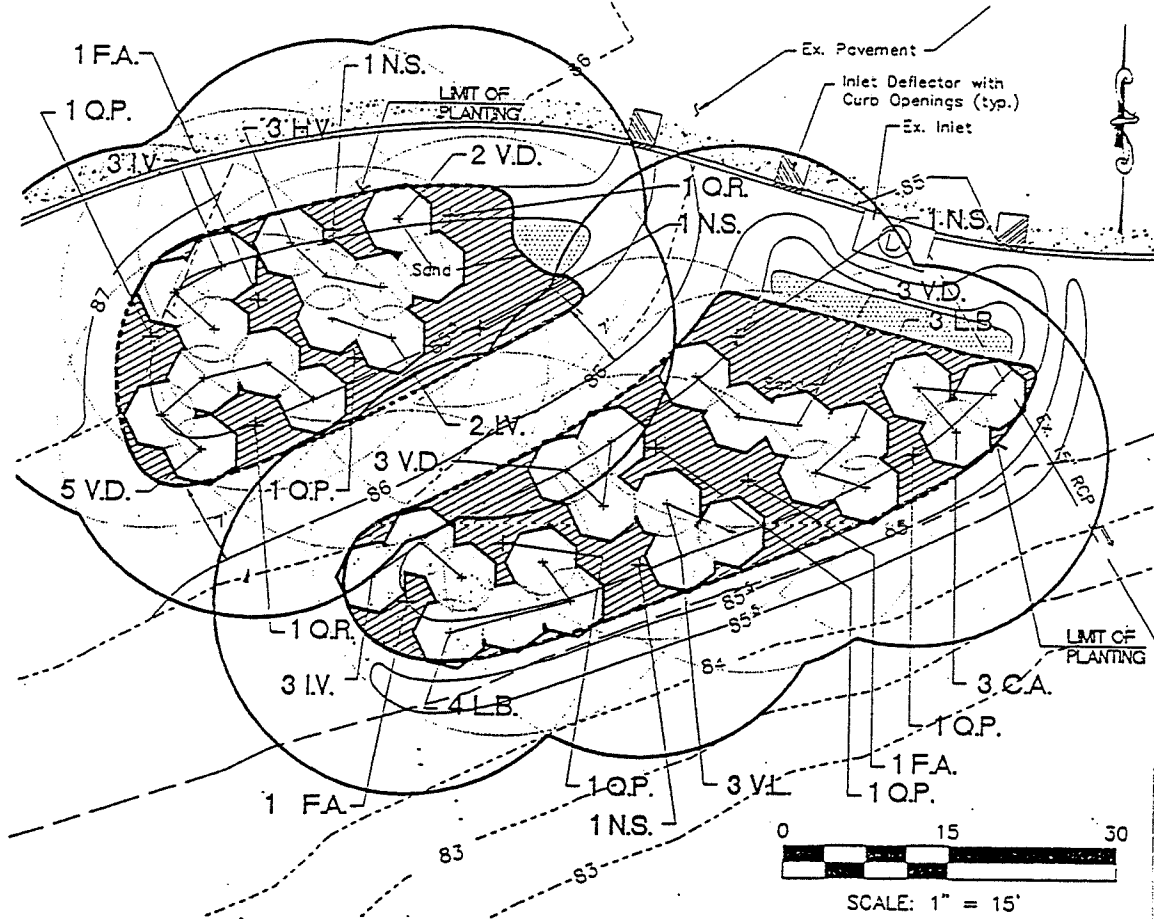

Often designers will find that the environmental factors such as wind and temperature vary not only on site but also between bioretention areas. As a result, the designer may need to consider the placement of each plant. An example would be to consider placing evergreen trees or other wind tolerant species on the northern end of a bioretention area, against cold winter winds.

The final plant material layout should resemble a random and natural placement of plants rather than a standard landscaped approach with trees and shrubs in rows or other orderly fashion. The most important goal dictating each consideration is to provide optimal conditions for plant establishment and growth. The idea of presenting bioretention areas as landscaped areas should not be the main focus of a bioretention design; however, the goals of the bioretention system can be achieved without sacrificing aesthetics.

Figure 14. Sample Planting Plan, From Prince George's Co, 1993



PLANTING PLAN LEGEND

- | | | | |
|---|------------------|---|----------|
|  | HERBACEOUS COVER |  | SAND BED |
|  | TREE |  | SHRUB |

TREE

SYMBOL	SCIENTIFIC NAME	COMMON NAME
F.A.	<i>Fraxinus americana</i>	white ash
N.S.	<i>Nyssa sylvatica</i>	black gum
Q.P.	<i>Quercus palustris</i>	pin oak
Q.R.	<i>Quercus rubra</i>	red oak

SHRUB

SYMBOL	SCIENTIFIC NAME	COMMON NAME
C.A.	<i>Clethra alnifolia</i>	sweet pepperbush
H.V.	<i>Hamamelis virginica</i>	witch hazel
I.V.	<i>Ilex verticillata</i>	winterberry
L.B.	<i>Lindera benzoin</i>	spicebush
V.D.	<i>Viburnum dentatum</i>	arrowwood
V.L.	<i>Viburnum lentago</i>	nannyberry

V. Soil, Mulch, and Plant Material Guidelines

A. Planting Soil Guidelines

The characteristics of the soil play an important role in the improvement of water quality through the use of bioretention systems. The soil is a three-phase system composed of gas, liquid, and solid, each of which in the proper balance is essential to the pollutant removal achieved through bioretention. The soil anchors the plants and provides nutrients and moisture for plant growth. Microorganisms inhabit and proliferate within the soil solution, and the unsaturated pore space provides plant roots with the oxygen necessary for metabolism and growth. A desirable planting soil for bioretention must be permeable to allow infiltration of runoff and provide adsorption of organic nitrogen and phosphorus.

The recommended planting soil for bioretention would have the following properties:

1. Soft Texture and Structure

It is recommended that the planting soils for bioretention have a sandy loam, loamy sand, or loam texture. Suitable planting soils for bioretention areas are indicated on the soil triangle in Figure 15. These soils have a clay content ranging from 10 to 25 %. Water balance computations in Section VIII indicate that soils with infiltration rates greater than 0.5 in/hr are suitable for bioretention. Sandy loam, loamy sand, and loam soils have minimum infiltration rates ranging from 0.52 to 2.41 in/hr. Other types of loamy soils such as silt loams, and sandy clay loams have infiltration rates of 0.27 in/hr or lower and are not suitable for bioretention.

2. Soil Acidity

In a bioretention scheme, the desired soil pH would lie between 5.5 and 6.5 (Tisdale and Nelson, 1975). The soil acidity affects the ability of the soil to adsorb and desorb nutrients, and also affects the microbiological activity in the soil.

3. Soil Testing

The planting soil for bioretention areas must be tested prior to installation for pH, organic matter, and other chemical constituents. The soil should meet the following criteria (Landscape Contractors Association, 1986):

pH range:	5.5 - 6.5
Organic matter:	1.5 - 3.0%
Magnesium (Mg):	35 lbs./acre
Phosphorus (P ₂ O ₅):	100 lbs./acre
Potassium (K ₂ O):	85 lbs./acre
Soluble salts:	not to exceed 500 ppm

It is recommended that one test for magnesium, phosphorus, potassium, and soluble salts be performed per borrow source or for every 500 cubic yards of soft material. It is recommended that a sieve analysis, pH, and organic matter test be performed per bioretention area.

Figure 15. Soil Triangle of the Basic Textural Classes, From Prince George's Co, 1993

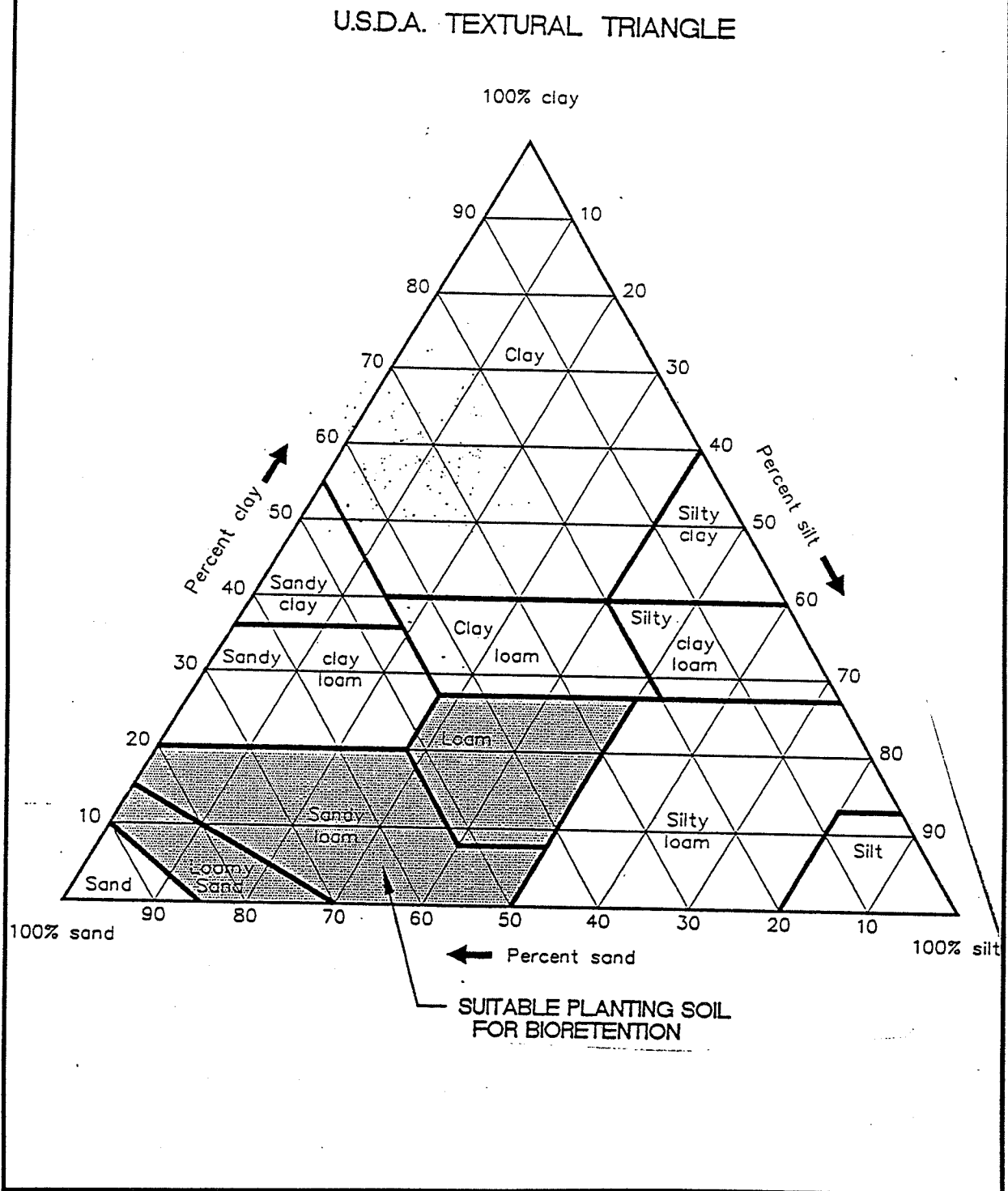

4. Soil Placement

Placement of the planting soil in the bioretention area should be in lifts of 18 inches or less and lightly compacted. Minimal compaction effort can be applied to the soil by tamping with a bucket from a dozer or a backhoe. Sample specifications relating to the planting soil are contained in Section IX.

B. Mulch Layer Guidelines

The mulch layer plays an important role in the overall bioretention design. This layer serves to prevent erosion and to protect the soil from excessive drying. Soil biota existing within the organic and soil layer are important in the filtering of nutrients and pollutants and assisting in maintaining soil fertility. Bioretention areas can be designed either with or without a mulch layer. If a dense herbaceous layer or groundcover (70 to 80% coverage) is provided, a mulch layer is not necessary. Areas should be mulched once trees and shrubs have been planted. Any ground cover specified as plugs may be installed once mulch has been applied.

The mulch layer recommended for bioretention may consist of either a standard landscape fine shredded hardwood mulch or shredded hardwood chips. Both types of mulch are commercially available and provide some protection from erosion.

The mulch should be aged (stockpiled) for a minimum of six months before being applied to bioretention areas. However, an optimal age for mulch is twelve months. Mulch should be free of weed seeds, soil, roots, or any other substance not consisting of either bole or branch wood and bark. The mulch should be uniformly applied approximately 2 to 3 inches in depth. Mulch applied any deeper than three inches reduces proper oxygen and carbon dioxide cycling between the soil and the atmosphere.

Grass clippings are unsuitable for mulch, primarily due to the excessive quantities of nitrogen stored in the material. Adding large sources of nitrogen would limit the capability of bioretention areas to filter the nitrogen associated with runoff.

C. Plant Material Guidelines

1. Plant Material Source

The plant material should conform to the current issue of the American Standard for Nursery Stock published by the American Association of Nurserymen. Plant material should be selected from certified nurseries that have been inspected by state or federal agencies. The botanical (scientific) name of the plant species should be in accordance with a standard nomenclature source such as Gray's Manual of Botany (Fernald, 1950).

Some of the plant species listed in Table IV. 1, (Recommended Plant Species For Use in Bioretention) may be unavailable from standard nursery sources. Designers may need to contact nurseries specializing in native plants propagation. All plant material specified must be propagated, germinated or otherwise developed from nurseries located in approximately the same Hardiness Zone.

2. Installation

The success of bioretention areas is very dependent on the proper installation specifications that are developed by the designer and subsequently followed by the contractor. The specifications include the procedures for installing the plants and the necessary steps taken before and after installation. Specifications designed for bioretention should include the following considerations:

- Sequence of Construction
- Contractor's Responsibilities
- Planting: Schedule and Specifications
- Maintenance
- Warranty

The sequence of construction describes site preparation activities such as grading, soil amendments, and any pre-planting structure installation. It also should address erosion and sediment control procedures. Erosion and sediment control practices should be in place until the entire bioretention area is completed.

The contractor's responsibilities should include all the specifications that directly affect the contractor in the performance of his or her work. The responsibilities include any penalties for unnecessarily delayed work, requests for changes to the design or contract, and exclusions from the contract specifications such as vandalism to the site, etc.

The planting schedule and specifications include type of material to be installed (e.g., ball and burlap, bare root, or containerized material), timing of installation, and post installation procedures. Balled and burlapped and containerized trees and shrubs should be planted during the following periods: March 15 through June 30 and September 15 through November 15. Ground cover excluding grasses and legumes can follow tree and shrub planting dates. Grasses and legumes typically should be planted in the spring of the year. The planting schedule and plan should address the following items:

- transport of plant material
- preparation of the planting pit
- fertilization
- installation of plant material
- stabilization: seeding (if applicable)
- watering and general care

An example of general planting specification for trees and shrubs and ground cover is given in Section X

3. Warranties

Typically, a warranty is established as a part of any plant installation project. The warranty covers all components of the installation for which the contractor is responsible. The plant and mulch installation for bioretention should be performed by a professional landscape contractor. An example of standard guidelines for landscape contract work is provided below:

- The contractor shall maintain a one (1) year 80% care and replacement warranty for all planting
- The period of care and replacement shall begin after inspection and approval of the complete installation of all plants and continue for one year
- Plant replacements shall be in accordance with the maintenance schedule

D. Plant Growth and Soil Fertility

An understanding of plant growth and soil fertility development over time is important for estimating the success and life span of bioretention areas. The physical, chemical, and biological factors influencing plant growth and development will vary over time as well as for each bioretention area. However, there are certain plant and soil processes that will be the same for all bioretention areas.

1. Plant Growth

The role of plants in bioretention includes uptake of nutrients and pollutants and evapotranspiration of stormwater runoff. The plant material, especially ground covers, are expected to contribute to the evapotranspiration process within the first year of planting. However, trees and shrubs that have been recently planted demonstrate slower rates of growth for the second year due to the initial shock of transplanting. The relative rate of growth is expected to increase to normal rates after the second growth season.

The growth rate for plants in bioretention areas will follow a similar pattern to that of other tree and shrub plantings (reforestation projects, landscaping). For the first two years, the majority of tree and shrub growth occurs with the expansion of the plant root system. By the third or fourth year the growth of the stem and branch system dominates increasing the height and width of the plant. The comparative rate of growth between the root and stem and branch system remains relatively the same throughout the life span of the plant. The reproductive system (flowers, fruit) of the plants is initiated last.

The growth rates and time for ground covers to become acclimated to bioretention conditions is much faster than for trees and shrubs. The rate of growth of a typical ground cover can often exceed 100 percent in the first year. Ground covers are considered essentially mature after the first year of growth. The longevity of ground covers will be influenced by soil fertility and chemistry as well as physical factors, such as shading and overcrowding from trees and shrubs and other ecological and physical factors.

Plants are expected to increase their contribution to the bioretention concept over time, assuming that growing conditions are suitable. The rate of plant growth is directly proportional to the environment in which the plant is established. Plants grown in optimal environments experience greater rates of growth. One of the primary factors determining this is soil fertility.

2. Soil Fertility

Initially soil in bioretention areas will lack a mature soil profile. It is expected that over time discrete soil zones referred to as horizons will develop. The development of a soil profile and the individual horizons is determined by the influence of the surrounding environment including physical, chemical, and biological processes. Two primary processes important to horizon development is microbial action and the percolation of water in the soil.

Horizons expected to develop in bioretention areas include an organic layer, followed by two horizons where active leaching (eluviation) and accumulation (illuviation) of minerals and other substances occur. The time frame for the development of soil horizons will vary greatly. As an average, soil horizons may develop within three to ten years. The exception to this is the formation of the organic layer often within the first or second year (Brady, 1984).

The evaluation of soil fertility in bioretention may be more dependent on the soil interactions relative to plant growth than horizon development. The soil specified for bioretention is important in filtering pollutants and nutrients as well as for supplying plants with water, nutrients, and support. Unlike plants that will become increasingly beneficial over time, the soil will begin to filter the stormwater runoff immediately. It is expected that the ability to filter pollutants and nutrients may decrease over time, reducing the soil fertility accordingly. Substances from runoff such as salt and heavy metals eventually disrupt normal soil functions by lowering the cation exchange capacity (CEC). The CEC, the ability to allow for binding of particles by ion attraction, decreases to the point that the transfer of nutrients for plant uptake can not occur. However, the environmental factors influencing each bioretention area will vary enough that it is difficult to predict for the life span of soils. Findings from other stormwater management systems suggest an accumulation of substances eliminating soil fertility within five years. The monitoring of soil development in bioretention areas will help develop better predictions on soil fertility and development and measures to restore soil fertility.

VI. Maintenance Guidelines

A schedule of recommended maintenance for bioretention areas is given in Table VI.1. The table gives general guidance regarding methods, frequency, and time of year for bioretention area maintenance.

A. Planting Soil

Urban plant communities tend to become very acidic due to precipitation as well as the influences of stormwater runoff. For this reason, it is recommended that the application of an alkaline substance, such as limestone, be considered once or twice a year. Testing of the pH of the organic layer and soil should precede the limestone application to determine the amount of limestone required.

Soil testing should be conducted annually so that the accumulation of toxins and heavy metals can be detected or prevented. Over a period of time, heavy metals and other toxic substances will tend to accumulate in the soil and the plants. Data from other environs such as forest buffers and grass swales suggest accumulation of toxins and heavy metals within five years of installation. However, there is no methodology to estimate the level of toxic materials in the bioretention areas since runoff, soil, and plant characteristics will vary from site to site.

As the toxic substances accumulate, the plant biological functions may become impaired, and the plant may experience dwarfed growth followed by mortality. The biota within the soil can also perish and the natural soil chemistry may be altered. The preventative measures would include the removal of the contaminated soil. In some cases, removal and disposal of the entire soil base as well as the plant material may be required.

B. Mulch

Bioretention areas should be mulched once the planting of trees and shrubs has occurred. Any ground cover specified as plugs may be installed once the area has been mulched. Ground cover established by seeding and/or consisting of grass should not be covered with mulch.

C. Plant Materials

An important aspect of landscape architectural is to design areas that require little maintenance. Certain plant species involve maintenance problems due to dropping of fruit or other portions of the plant. Another

problem includes plants, primarily trees, that are susceptible to windthrow, which creates a potential hazard to people and property (parked cars). As a result, some plant species will be limited to use in low traffic areas.

Ongoing monitoring and maintenance is vital to the overall success of bioretention areas. Annual maintenance will be required for plant material, mulch layer, and soil layer. A maintenance schedule should include all of the main considerations discussed below. The maintenance schedule usually includes maintenance as part of the construction phase of the project and for life of the design.

Maintenance requirements will vary depending on the importance of aesthetics. Soil and mulch layer maintenance will most likely be limited to correcting areas of erosion. Replacement of mulch layers may be necessary every two to three years. Mulch should be replaced in the spring. When the mulch layer is replaced, the previous layer should be removed first. Plant material upkeep will include addressing problems associated with disease or insect infestations, replacing dead plant material, and any necessary pruning.

Table VI.1. Example Maintenance Schedule for Bioretention Areas			
Description	Method	Frequency	Time of year
Soil			
Inspect and Repair Erosion	Visual	Monthly	Monthly
Organic Layer			
Remulch any void area	By hand	Whenever needed	Whenever needed
Remove previous mulch layer before applying new layer (optional)	By hand	Once every two or three years	Spring
Any additional mulch added	By hand	Once a year	Spring
Plants			
Remove and replacement of all dead and diseased vegetation considered beyond treatment	See planting specifications	Twice a year	3/15 to 4/40 and 10/1 to 11/30
Treat all diseased trees and shrubs	Mechanical or by hand	N/A	Varies, but will depend on insect or disease infestation
Water of plant material shall take place at the end of each day for fourteen consecutive days and after planting has been completed	By hand	Immediately after completion of project	N/A
Replacement of support stakes	By hand	Once a year	Only remove stake in the spring
Replace any deficient stakes or wires	By hand	Whenever needed	Whenever needed

VII. Peak Runoff Control and Pollutant Reduction

This section will examine the peak runoff control and the pollutant reduction benefits of bioretention areas. At some sites local or state agencies may require peak flow attenuation in addition to the water quality protection that bioretention areas provide. This chapter will outline methodology that can be used to determine the reduction in peak runoff from bioretention methods.

This chapter will also discuss the pollutant removal from bioretention practices. Bioretention areas remove pollutants through a variety of physical, biological, and chemical treatment processes such as adsorption, flocculation/coagulation, ion exchange, decomposition and filtration. The amount of pollutant loading reduction required by the North Carolina's state stormwater management requirements is 85% reduction in TSS. The state assume that when designed, constructed, and maintained properly a bioretention area will provide a minimum of this level of treatment.

Bioretention areas can potentially provide peak runoff control in two ways:

- Increasing the time of concentration for a site using sheet flow, and,
- Providing storage for runoff.

The amount of peak; reduction provided by increasing the time of concentration and runoff storage can be readily determined using the methodology in the Soil Conservation Service Report TR-55 (U.S.D.A., 1986). According to the time-of-travel computation in TR-55, 25 feet of grass would add 0.1 hour to the time of concentration, compared to that of pavement. For a one-acre commercial Site that has a runoff curve number of 90, the time of concentration increase would reduce the 2 year runoff from 4 to 3 cfs.

Bioretention areas also have the capacity to infiltrate the first one inch of runoff. The following method can be used to determine the peak flow reduction from the infiltration of the first one inch of runoff. The first step is to determine the amount of runoff from the existing site from the design storm. For example, the runoff for the 2-year storm , 3.1 inches of rainfall, for a site having a curve number (CN) of 90 would be computed as follows:

$$\text{Runoff} = \frac{(P - 0.2 * S)^2}{(P + 0.8 * S)}$$

$$\text{Where: } P \text{ (Precipitation)} = 3.1 \text{ inches} \\ S = (1000/CN - 10) = 1.11 \text{ inches}$$

$$\text{Runoff} = \frac{(3.1 - 0.2 * 1.11)^2}{(3.1 + 0.8 * 1.11)}$$

$$\text{Runoff} = 2.39 \text{ inches}$$

The ratio of the infiltration volume to the runoff volume is 0.5/2.39 or .21. Entering .21 into Figure 6-1 of the TR-55 Manual as the ratio of storage to runoff volume (V_r/V_i), the ratio of peak outflow discharge to peak inflow discharge is 0.68, or a 32 % reduction in the 2- year storm.

VIII. Water Balance for Bioretention Areas

A. Water Balance Methodology

An example water balance was developed for a proposed bioretention area based on the precipitation, evapotranspiration and the infiltration for a commercial tract over a four-day time period. The four-day period was selected for hydrologic, horticultural, and maintenance constraints. Four days is the median time period between storms in the Washington area (EPA), and it would be undesirable for the soil in a bioretention area to remain saturated for more than four days. A ponding time in excess of four days would severely limit the potential plant species for the bioretention areas.

The overall objective of the water balance was to determine the amount of water to be infiltrated and diverted from the bioretention area as a result of varying amounts of precipitation. The bioretention area is composed of four components:

- ponding area (6" minimum)
- root zone for plants (4' minimum)
- sand bed surrounding the root zone
- in-situ material below the bed.

These four components are shown for the bioretention areas in Figures 6 through 9. The bioretention area used in the analysis was 15 feet wide by 40 feet long, which is the minimum size.

In the first part of the water balance simulation the site runoff enters both the sand bed surrounding the root zone and the root zone itself at the center of the bioretention area. The volume of ponded water is governed by the following relationship

Ponded Volume = Runoff Volume - Sand Bed Infiltration - Root Zone Infiltration.

Runoff is diverted from the bioretention area once the ponded volume is at its limit.

The water balance computations were run at one-hour intervals for the four-day (96-hour) time period using a spreadsheet computer program. The spreadsheet analysis was set up such that site, precipitation, and soil parameters can be varied. The development of the precipitation, evapotranspiration, and infiltration variables of the water balance are described below.

B. Parameters

1. Precipitation/Runoff

The water balance was determined for rainfall events of 0.5 and 0.7 inches. The rainfall distribution in the Metropolitan Washington Council of Governments manual, Controlling Urban Runoff, indicates that a rainfall of 0.7 inches would not be exceeded 80 percent of the time. The precipitation was assumed to occur over six hours, which is the median storm length for most of North Carolina (EPA, 1986).

In determining the runoff to the bioretention area, it was assumed that the commercial tract was over 80 percent impervious. This assumes a greater imperviousness than will be allowed in any Water Supply watershed, but this level is often reached in developments in the twenty coastal counties.

2. Evapotranspiration

Evapotranspiration (ET) is the aggregate term for the water use by the biological functions of plants, and the water loss from evaporation from the surface of the plant and the adjacent soil. There has been extensive research regarding the ET rate for various crops. It is general procedure to develop ET rates for "reference" crop species such as alfalfa, and adjust the ET rates for the species of interest. The monthly ET rates for alfalfa were computed using the Blaney-Criddle Potential Consumptive Use equation. The crop coefficient (K value) for alfalfa ranges from 0.80 to 0.85. The K Value for bioretention areas is comparable to the K value for deciduous orchards (0.6 to 0.7). Consequently, the ET rate for alfalfa was lowered by 15 % to develop the bioretention area rate.

The ET rate for alfalfa is summarized below in Table IV.2 for various months of the year. The ET rates were computed using mean monthly temperatures, wind speed, and other weather data compiled by the University of Maryland Agricultural Experiment Station for Prince George's County. It should be noted that there is no appreciable ET for the months of November through March. Even though ET rates are shown for Maryland, the computation of rates can be calculated for NC and are similar to rates in Maryland.

Table IV.2. Evapotranspiration Rates for Reference Crop Species (Alfalfa) and for Bioretention Areas

Evapotranspiration (inches)		
Month	Reference Crop (Alfalfa)	Bioretention Areas
April	2.88	2.45
May	5.56	4.73
June	7.74	6.58
July	8.66	7.36
August	6.56	5.58
September	4.50	3.83
October	2.64	2.24

The ET rate for the month of July, 7.36 in/month, was used in the water balance example.

3. Infiltration

Throughout the water balance, water infiltrates from the ponded area to the root zone, from the root zone onto the sand layer and finally from the sand layer into the in-situ material or to the underdrain. The infiltration rates for the sand, soil, and in-situ material were taken from the State of Maryland Manual on Infiltration Practices. The infiltration rates used in the water balance are given in Table IV.3 for the components of the bioretention area. These will not apply if an underdrain is used.

Table IV.3. Infiltration Rates for Bioretention Components		
Bioretention Component	Soil Type	Infiltration Rate (in/hr)
Sand Bed	Sand	8.27
Root Zone	Loamy Sand	2.41
	Sandy Loam	1.02
	Loam	0.52
In-Situ Material	Silt Loam	0.27
	Sandy Clay Loam	0.17
	Clay Loam	0.09

In the water balance, the rate of sand and soil infiltration was initially set at the maximum rate until 80 percent of the layer was saturated. After 80 percent saturation was achieved, the infiltration rate was set to:

$$\text{Infiltration Rate} = \text{Max Rate} * (1 - \text{Saturation Fraction})$$

C. Results

The results of the water balance indicate that the minimum sized bioretention area of 15 by 40 feet will infiltrate runoff for a site area of 0.2 acres for a rainfall of 0.7 inches. The runoff from a slightly larger site area of 0.3 acres can be infiltrated for a 0.5 inch rainfall. Under the most conservative scenario for the 0.7 inch rainfall, the bioretention area would comprise 7% of the site area. Since bioretention would be located in parking islands which are required by many local governments, bioretention practices might not significantly increase the existing landscape requirements.

The water balance is based on the root zone soil being comprised of a loam having an infiltration rate of 0.52 inches per hour, and an in-situ soil infiltration rate of 0.2 inches per hour. In-situ or root zone soils with lower infiltration rates would lower the capacity of the bioretention area below design limits.

The water balance was also used to determine the ponding volume, and percentage of saturation for the sand and root zone soil, for the 0.5 and 0.7 inch rainfall events. The plots indicate that the total ponding time in the bioretention area is 16 hours, which is well below the four-day maximum time period allowed. The plots also indicate that the sand and soil are partially saturated for 70 hours of the 96-hour (4-day) time period, and aerobic conditions would exist in the soil for the 0.7 inch rainfall.

IX. Bioretention Area: Soil Specifications

A. Planting Soil

The bioretention areas shall consist of a planting soil having a composition of at least 10 to 25 percent clay and shall be of a sandy loam or loamy sand texture. Loamy soils may be utilized for the planting soil but must consist of 35% sand. In addition, the furnished planting soil shall be of uniform composition, free of stones, stumps, roots or similar objects larger than one inch, brush, or any other material or substance which may be harmful to plant growth, or a hindrance to planting or maintenance operations.

The planting soil shall be free of plants or plant parts of Bermuda grass, Quack grass, Johnson grass, Mugwort, Nutsedge, Poison Ivy, Canadian Thistle or others as specified.

It shall not contain toxic substances harmful to plant growth.

The planting soil shall be tested and meet the following criteria:

pH range	5.5 - 6.5
Organic matter	1.5 - 3.0%
Magnesium - Mg	35 lbs./acre
Phosphorus -P2O5	100 lbs./acre
Potassium - K2O	85 lbs./acre
Soluble salts	not to exceed 500 ppm

The following testing frequencies shall apply to the above soil constituents:

- pH, Organic Matter: 1 test per 90 cubic yards, but no more than 1 test per Bioretention Area
- Magnesium, Phosphorus, Potassium, Soluble Salts: 1 test per 500 cubic yards, but no less than 1 test per borrow source
- One grain size analysis shall per performed per 90 cubic yards of planting soil, but no less than 1 test per Bioretention Area.

B. Mulch Layer Specifications

A mulch layer shall be provided on top of the planting soil. An acceptable mulch layer shall include shredded hardwood or shredded wood chips or other similar material.

Of the approved mulch products, all must be well aged, uniform in color, and free of foreign material including plant material. Well-aged mulch is defined as mulch that has been stockpiled or stored for at least twelve (12) months.

C. Sand Specifications

The sand shall be free of deleterious material and rocks greater than 1 inch in diameter.

D. Compaction

Soil shall be placed in layers less than 18 inches and lightly compacted (minimal compactive effort) by tamping with a bucket from a dozer or a backhoe.

X. Bioretention Area: Plant Specifications

General Planting Specifications

- Root stock of the plant material shall be kept moist during transport from the source to the job site and until planted.
- Walls of planting pit shall be dug so that they are vertical.
- The diameter of the planting pit must be a minimum of six inches (6") larger than the diameter of the ball of the tree.
- The planting pit shall be deep enough to allow 1/4" of the ball to be above the existing grade. Loose soil at the bottom of the pit shall be tamped by hand.
- The appropriate amount of fertilizer is to be placed at the bottom of the pit (see below for fertilization rates).
- The plant shall be removed from the container and placed in the planting pit by lifting and carrying the plant by its' ball (never lift by branches or trunk).
- Set the plant upright and in the center of the pit so that the top of the ball is approximately 1/4" above the final grade.
- Backfill planting pit with existing soil.
- Make sure plant remains straight during backfilling procedure.
- Never cover the top of the ball with soil. Mound soil around the exposed ball (1/4").
- Trees shall be braced by using 2" by 2" white oak stakes. Stakes shall be placed parallel to walkways and buildings. Stakes are to be equally spaced on the outside of the tree ball. Utilizing hose and wire, the tree is braced to the stakes.

Fertilization

- Tree and shrub fertilizer shall be a 21-gm, tightly compressed, long lasting, slow release (2 year) fertilizer tablet with a minimum guaranteed analysis of 20-10-5:

Total Nitrogen: (N) - 20%
Water Soluble Organic Nitrogen - 7 %
Water Insoluble Organic Nitrogen - 13%
Available Phosphoric Acid (P₂O₅) - 10%
Soluble Potash (K₂O) - 5 %

For containerized trees and shrubs, place the specified fertilizer tablet(s) in the bottom of the planting pit according to the following rates:

1 gal. Container	1 ea. 21 gm. Tablets
3 gal. Container	2 ea. 21 gm. Tablets
5 gal. Container	3 ea. 21 gm. Tablets
7 gal. Container	5 ea. 21 gm. Tablets

Planting Non-Grass Ground Cover

- The ground cover planting holes shall be dug through the mulch with one of the following: hand trowel, shovel, bulb planter, or hoe (this does not apply to grasses or legumes).
- Before planting, biodegradable pots shall be split, and non-biodegradable pots shall be removed. Root systems of all potted plants shall be split or crumbled.
- The ground cover shall be planted so that the roots are surrounded by the soil below the mulch. Potted plants shall be set so that the top of the pot is even with the existing grade. The roots of bare root plants shall be covered to the crown.
- Before planting, apply a pre-emergent herbicide to the mulched and planted ground cover bed.
- The entire ground cover bed shall be thoroughly watered.

Planting Grass Ground Cover

Grasses and legume seed shall be tilled into the soil to a depth of at least 2 inches by either harrowing or discing. Fertilizer shall be applied at the same rate and utilizing the same process for non-grass ground cover. Grass and legume plugs shall be planted following the non-grass ground cover planting techniques.

All ground covers shall be fertilized with a 10-6-4 analysis fertilizer as a wet application at the rate of 3 lbs. per 100 square feet of the bioretention area prior to planting non-grass ground cover or as part of the grass seed ground cover.

XI. References

Brady, N.C. 1984. The Nature and Properties of Soils. MacMillan Publishing Co., New York, New York.

Correll, D. March 20, 1992, Personal communication by PGCDER staff. Smithsonian Environmental Research Center. Edgewood, Maryland.

Correll, D. and Peterjohn, W.T. 1984. Nutrient Dynamics in an agricultural watershed: observations on the role of a riparian forest, Ecology, 65(5). 1984. pp. 1466 - 1475.

Criddle, W.D. 1958. Methods of computing consumptive use of water. Proceedings ASCE, Div. Irrigation and Drainage 84:1-27.

Fernald, M.L., 1950. Gray's Manual of Botany, eighth edition. Dioscorides Press, Portland, Oregon

Lindsley, R.K., Kohler, M.A. and Paulhus, J.L.H., 1958. Hydrology for Engineers, Second Edition, McGraw-Hill, Inc., 328 pp.

Gounin, F., 1992. Personal Communication by PGCDER staff, University of Maryland, College Park, Maryland, March 17.

Hightshoe, G.L., 1988. Native Trees, Shrubs, and Vines for Urban and Rural America. Van Nostrand Reinhold, New York, New York.

Maryland Department of Natural Resources (MDNR), Water Resources Administration (WRA), 1984. "Maryland Standards and Specifications for Stormwater Management Infiltration Practices", Stormwater Management Division, Tawes State Office Building, Annapolis, Md. 21401. p. 2-23.

Metropolitan Washington Council of Governments, 1992. Watershed Restoration Sourcebook: Collected Papers presented at the 1991 Conference; "Restoring our Home River".

Moyer, W.J. and R.C. Moyer. 1987. Climate of Upper Marlboro, Maryland, Contribution No. 7571, and Experiment Station Bulletin No. 13 of the Maryland Agricultural Experimental Station, The University of Maryland., 69 pp.

North Carolina Department of Environment, Health, and Natural Resources, Division of Land Quality, Raleigh, NC. September 1988. Erosion and Sediment Control Planning and Design Manual.

Prince George's County, Department of Environmental Resources (DER), 1991, Stormwater Management Design Manual., Appendix 4-5, 2 pp.

Prince George's County. October 1989. Prince George's County Landscape Manual. Prince George's County, Maryland.

Reed, P.B. Jr., 1988. National List of Species That Occur in Wetlands: Northeast. United States Fish and Wildlife Service, St. Petersburg Florida.

Schlesinger, W. H. and Waring, R.H. 1985. Forest Ecosystems: Concepts and Management. Academic Press. Orlando, Florida., pp. 416-418.

Schueler, T. 1987. Controlling Urban Runoff: A Practical Manual for Planning and Designing Urban BMPs. Metropolitan Washington Council of Governments. pp.416 - 418.

Tisdale, S.L. and Nelson, W.L., 1975,. Soil Fertility and Fertilizers, Third Edition, Macmillan Publishing Co., Inc., New York, 694 pp..

U.S. Department of Agriculture, Soil Conservation Service, 1986. Urban Hydrology for Small Watersheds, Engineering Division, Technical Release 55, June, 1986. p 3.3 .

U.S. Environmental Protection Agency (USEPA), 1986. Methodology for Analysis of Detention Basins for the Control of Urban Runoff Quality, Office of Water Nonpoint Source Branch, Washington, D.C. 20460, EPA440/5-87-001. pp. A-5 - A-10.

Chapter 5 Grassed Swales

I. Introduction

Grassed swales are shallow trapezoidal or parabolic earthen channels covered with a dense growth of a hardy grass such as Reed Canary or Tall Fescue. Grassed swales are sometimes classed as a type of biofilter because the vegetation on the swale takes up some pollutants and helps filter sediment and other solid particles out of the runoff. These channels convey stormwater and provide some stormwater management for small storms by retarding peak flow rates, lowering velocities of runoff and by infiltrating runoff water into the soil. Swales are used primarily in single-family residential developments, at the outlets of road culverts, and as highway medians.

Enhanced grassed swales are ordinary swales with small check dams and wide basins along their course (Schueler, et al 1992). The check dams and the wide areas create small pools of water, which slow the water's flow, encourage the water to infiltrate into the soil and enhance pollutant removal. Figure 16. show an example of an enhanced grass swale.

The Erosion and Sediment Control Planning and Design Manual for North Carolina describes the process of swale design in detail, and the designer should consult it for general design and vegetation specifications. When a swale is designed and installed for the purpose of water quality protection in addition to the basic purpose of transporting stormwater, the design velocities are lower. The requirements for reduced velocities are to allow a greater contact time with the vegetation and to allow for more infiltration.

Grassed swales have a long history of use for stormwater conveyance, and they normally provide long-term water quality protection. However, because of their limited pollutant removal ability, grassed swales are not a sufficient means to reach the 85% TSS removal requirement, but they can be used as one of a series of BMPs that when combined with other BMPs, can provide sufficient protection to surface waters. An example would be a development that used a combination of grassed swales and extended dry detention to achieve the required 85% TSS removal. For the purposes of satisfying the requirements for stormwater treatment found in NCAC 15A 2H.1000, a properly designed and constructed grass swale is assumed to have a TSS removal of 35%.

II. General Characteristics

Grassed swales have had mixed results in removing particulate pollutants such as sediment and trace metals. They are generally unable to remove significant amounts of soluble plant nutrients. Swales have proven to be very reliable with few failures. However, formation of gullies or thinning of the vegetative cover will reduce pollutant removal and cause the swale to fail as a pollutant-removing device.

III. Advantages

The primary advantages of grassed swales include relatively low construction and maintenance costs, increased infiltration, additional wildlife habitat in some cases, elimination of curbs and gutters which collect and deliver pollutants to receiving waters, and a pleasing appearance. In areas with low amounts of impervious surface, such as single-family residential areas, curbs and gutters can be replaced by swales, resulting in increased stormwater pollutant removal and improved aesthetics.

Figure 16. Enhanced Grassed Swale, From Stormwater Management Guidance Manual, NC, 1993, Adapted from Schueler, 1987

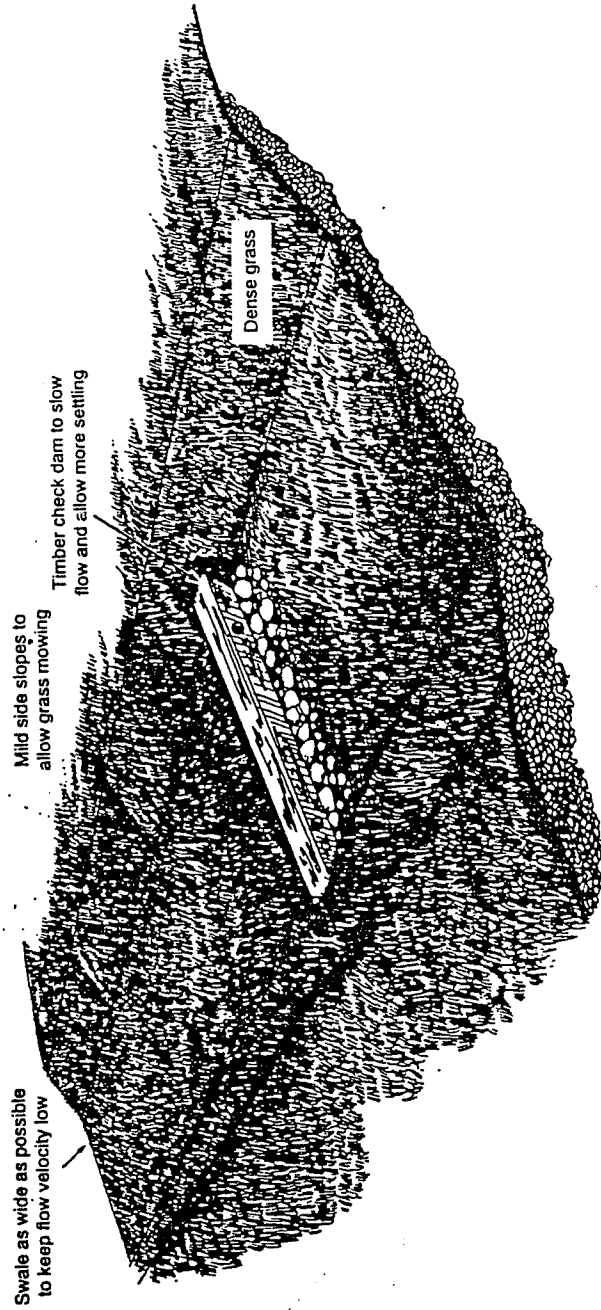

IV. Disadvantages

Disadvantages of swales include limited pollutant removal, increased nutrient concentrations in runoff due to fertilization of the grass in the swales, and standing water, which may cause safety, odor and/or mosquito problems.

V. Costs

Swales cost less to construct than curbs, gutters, and underground pipes; however, swales take up more land area. The costs of maintaining swales are usually minimal. However, special maintenance such as extensive sediment removal or erosion repair may become expensive.

VI. Design Requirements:

- Longitudinal slope should be in the range of 2 to 4%. If slope along the flow path exceeds 4%, then checkdams must be installed to reduce the effective slope to below 4%.
- Side slopes should be no greater than 3:1 horizontal to vertical.
- Maximum runoff velocity should be 2 fps for the peak runoff of the 2 year storm.
- Design must also nonerosively pass the peak runoff rate from the 10 yr. storm.
- Length of swale shall be at least 100 feet per acre of drainage area.
- A vegetation plan shall be prepared in accordance with the recommendation found in Erosion and Sediment Control Planning and Design Manual.
- Swales should be stabilized within 14 days of the swales construction.

Other general recommendation for design and construction of grassed swales for pollutant removal follow:

- Swales should be constructed on permeable, noncompacted soils.
- Swales should be sited in areas where the seasonal high water table is at least one foot below the bottom of the swale.
- Swales should not carry dry-weather flows or constant flows of water; and
- Swales should have short contact times or short grass height.

VII. Maintenance

Swale maintenance basically involves normal grass management growing activities such as mowing and resodding when necessary and periodic sediment removal, if significant deposition occurs. Maintenance shall be performed as follows:

- At least once annually, remove excess sediment, especially from the upstream edge, to maintain original contours and grading.
- At least once annually, repair any erosion and regrade the swale to ensure that the runoff flows evenly in a thin sheet through the swale.
- At least once annually, inspect vegetation and revegetate the swale to maintain a dense growth of vegetation.
- Grassed swales shall be mowed at least twice annually to a minimum height of six inches.

VIII. References

- Arnold, J.A., ed. D.E. Line, S.W. Coffey, and J. Spooner. 1993. Stormwater Management Guidance Manual. North Carolina Cooperative Extension Service and North Carolina Division of Environmental Management. Raleigh, NC
- Berman, Laurel, C. Hartline, N. Ryan, and J.D. Thorne, P.E. 1991. Urban Runoff: Water Quality Solutions. The American Public Works Association Research Foundation. 58 pp.
- Birch, P.B., Ph.D. and H.E. Pressley (eds.) 1992. Stormwater Management Manual for the Puget Sound Basin. Review Draft. Dept. of Ecology. Publication number 90-73.
- Gibb, A., B. Bennett, and A. Birkbeck. 1991. Urban Runoff Quality and Treatment: A Comprehensive Review. File number 2-51-246(242). British Columbia Research Corporation. Vancouver, British Columbia.
- North Carolina Department of Environment, Health, and Natural Resources, Division of Land Quality, Raleigh, NC. September 1988. Erosion and Sediment Control Planning and Design Manual.
- Schueler, T.R., P. A. Kumble, and M. A. Heraty. 1992. A Current Assessment of Urban Best Management Practices: Techniques for Reducing Non-Point Source Pollution in the Coastal Zone. Publication number 92705. Metropolitan Washington Council of Governments. Washington, DC. 127 pp.
- Schueler, T.R. 1987. Controlling Urban Runoff: A Practical Manual for Planning and Designing Urban BMPs. Publication number 87703. Metropolitan Washington Council of Governments. Washington, DC. 275 pp.
- Stahre, P. and B. Urbonas. 1990. Stormwater Detention For Drainage, Water Quality, and CSO Management. Prentice Hall, Inc. Englewood Cliffs, NJ. 338 pp.
- U.S. EPA. 1990. Urban Targeting and BMP Selection. Information and Guidance Manual for State Nonpoint Source Program Staff Engineers and Managers. The Terrene Institute. EPA No. 68-C8-0034. 54 pp.
- U.S. EPA. 1992. Stormwater Management for Industrial Activities: Developing Pollution Prevention Plans and Best Management Practices. Office of Water. Government Institutes, Inc. Rockville, MD.
- Urbonas, B. and L.A. Roesner, eds. 1986. Urban Runoff Quality--Impact and Quality Enhancement Technology. American Society of Civil Engineers. New York, NY. 477 pp.
- Whipple, W., N.S. Grigg, T. Grizzard, C. W. Randall, R. P. Shubinski, and L. S. Tucker. 1983. Stormwater Management in Urbanizing Areas. Prentice Hall, Inc. Englewood Cliffs, NJ. 234 pp.

Chapter 6 Extended Dry Detention Basins

I. Introduction

Dry detention basins are also called dry ponds, dry detention ponds and detention basins. These basins have been the workhorse for control of stormwater peak flows in other states and in some areas of North Carolina for years; hence, there is a fair body of knowledge to assist in their design and operation. Their use as a water quality BMP is less well understood, and what data exists seems to suggest that basins designed only for peak flow attenuation do not provide significant water quality benefits. The topic of this section, Extended Dry Detention Basin, is similar to the conventional dry basins, but provides for a longer detention time for a more frequent storm. Figure 17. show an example of an extended dry detention basin.

The conventional design of dry detention basins is to simply hold or detain stormwater for a short interval of time, at least 24 hours, to reduce the peak flows in the receiving water. The basin should dry out between storms. Primary design values for detention basins are: the detention time [which is the amount of time the stormwater is held in the basin before being discharged] and the basin volume [which determines the amount of runoff that can be held for the desired length of time.]

With the present emphasis on improving stormwater quality, new basins are designed to remove pollutants and existing basins can be modified to enhance pollutant removal. Since dry detention basins have not been demonstrated to provide the level of pollutant removal that is required under 15A NCAC 2H.1000, (i.e. that being the long term removal of 85% of the incoming TSS), they must be used in combination with other BMPs such as grassed swales.

II. Advantages

Dry detention basins are usually not limited by terrain or soils. They provide excellent streambank erosion protection and treatment of stormwater when used in combination with other stormwater control practices such as wetlands or when retrofitted with permanent pools. Modified dry basins can provide wetlands and wet meadows for animal habitat if the basins incorporate permanent pools and proper landscaping.

III. Disadvantages

Dry extended detention basins are usually considered unattractive by residents. Poorly maintained basins can create nuisance odors, breed insects and collect trash. Poorly located basins can remove valuable animal habitat and degrade streams and forests. Dry basins require a fair amount of land area, depending on the terrain of the land and are normally placed where they cannot be easily seen as most residents consider them unattractive.

IV. Costs

Detention basins are inexpensive compared to other stormwater control practices when only construction costs are considered. If land costs are high, then they can become one of the more expensive stormwater BMPs. Maintenance costs are higher than many other practices.

Figure 17. Extended Dry Detention Basin, From Stormwater Management Guidance Manual, NC, 1993

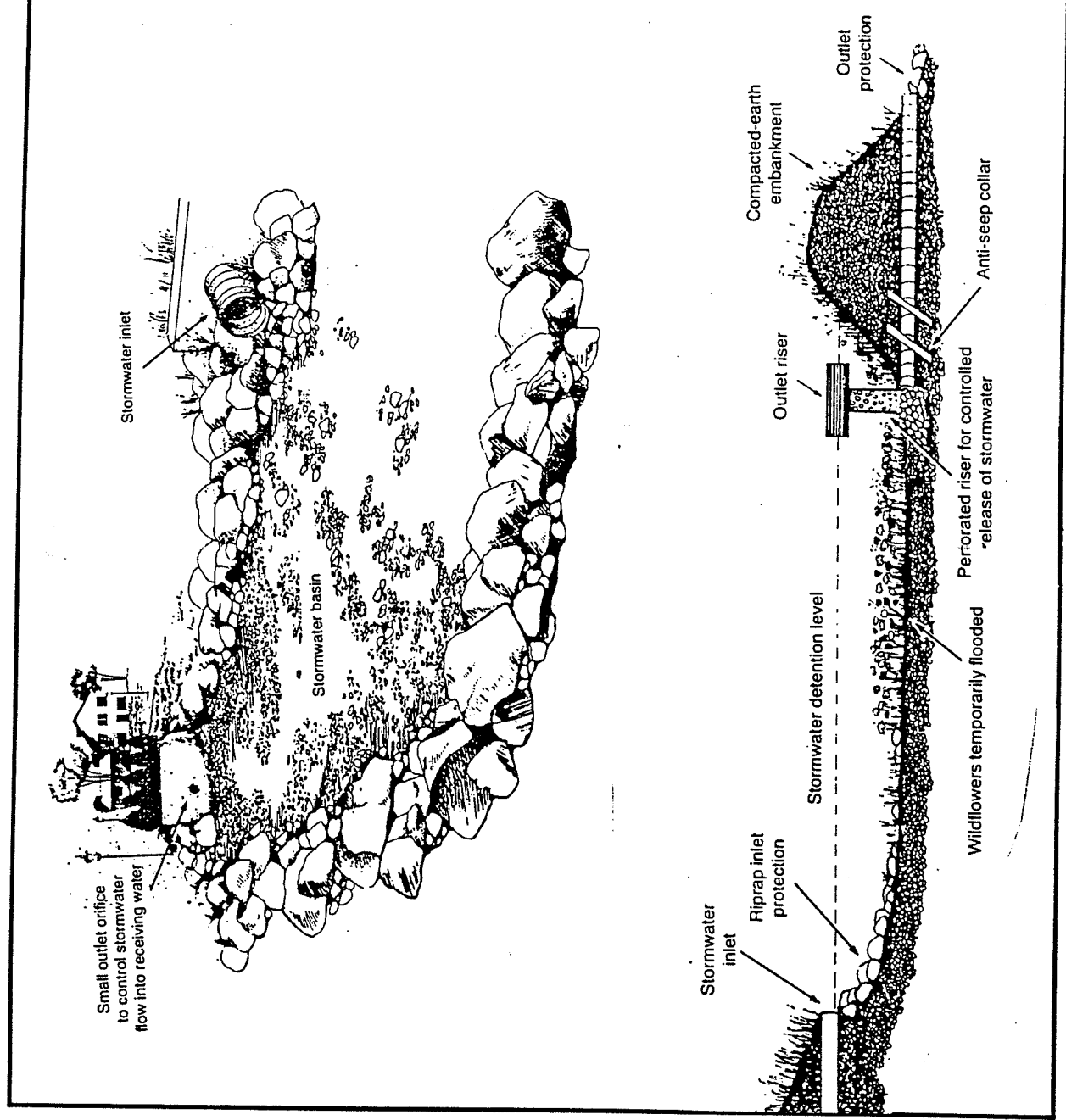

V. Design Requirements

- Extended dry detention basins must capture the runoff from the 1 yr., 24 hour storm and release it over a period of 48 hours, or
- Capture the runoff from the 1 inch storm and allow it to draw down over a period of 2 to 5 days.
- Minimum flow length to width ratio of 3:1.
- Sideslopes of the pond should be no steeper than 3:1 horizontal to vertical.
- Extended detention basins must include a small permanent pool near the outlet orifice to reduce clogging and keep floating debris away from the outlet.
- Cleanout access must be provided that is sufficient for heavy machinery.
- There must be a drain that will completely empty the basin for cleanout.
- Any additional peak flow control that the local government requires must be met.
- If the basin was used during construction as a sediment basin or trap, then the basin must be cleaned out, graded, and vegetated within 14 days of the completion of construction.
- There must be a vegetation plan prepared by a NC licensed professional. Consideration must be given to the grasses specified due to the frequent inundations.
- The basin must be stabilized within 14 days of construction. This might be in the form of final vegetation, or a temporary means of providing stabilization till the vegetation becomes established.
- The design must provide for the sediment storage in addition to the detention volume that is equal to 20% of the detention volume.
- Inlet and outlet channels should be protected from scour during high flows from large storms. Standard erosion control measures work very well. The Land Quality Section of the North Carolina Department of Health, Environment, and Natural Resources and the US Department of Agriculture Natural Resource Conservation Service (SCS) can provide valuable information on erosion and sediment control techniques.

The previous illustration, Figure 17, shows a cross-section of an extended detention pond that would meet the above criteria. It shows the use of an inverted pipe orifice that is submerged in the small permanent pool. This allows a more consistent prediction of drawdown time, and provide some protection from clogging.

VI. Additional Design Considerations:

- Sediments can be resuspended by the incoming runoff. Therefore it is recommended that there be either an additional plunge pool at the inlet of the basin, or sufficient measures such as riprap to disperse the energy.
- A forebay to capture sediment can minimize cleanout problems. It is a good idea to provide adequate access for equipment to be used for cleanout. Also, paving or flexible revetment in the forebay can allow for rapid access and quick sediment removal by heavy equipment.
- Consideration should be given to the soil type of the site of the basin. Uncompacted, natural soils will provide the best media for vegetation and will introduce less sediment in the incoming water.
- The seasonal high water table should be at least 1 foot below the bottom of the extended dry detention basin.

VII. Maintenance

Dry basins require frequent mowing and unclogging of outlets. Poorly designed basins with steep side slopes may be hazardous to mow with power equipment creating difficult and/or expensive maintenance. Trash, debris and sediment accumulation is rapid in most basins, requiring frequent cleaning.

Detention basins usually do not normally fail structurally; however, many dry detention basins are not functioning as designed mainly because they do not empty completely between storms. This reduces the effective storage volume and detention time for incoming storm flows.

Maintenance Requirements are as follows:

- All grassed areas of an extended dry detention basin should be mowed at least twice annually.
- Extended dry detention basins will tend to collect debris, and it should be removed whenever it accumulates, or at least twice annually.
- Pond should be inspected annually after a rain event to ensure that the basin is operating as designed.
- At a minimum, items that should be included in the inspection are:
 1. clogging of the outlet or too rapid a release,
 2. erosion on the banks,
 3. erosion at the inlet and outlet,
 4. sediment accumulation and the need for removal,
 5. condition of the emergency spillway, and
 6. woody vegetation in the embankment.

VIII. Peak Flow Reduction

Dry detention basins are normally used to reduce peak flows from storms of varying recurrence frequency. Their pollutant removal potential is enhanced when used in conjunction with permanent pools, wetlands, etc.

IX. References

Arnold, J.A., ed. D.E. Line, S.W. Coffey, and J. Spooner. 1993. Stormwater Management Guidance Manual. North Carolina Cooperative Extension Service and North Carolina Division of Environmental Management. Raleigh, NC

Berman, Laurel, C. Hartline, N. Ryan, and J.D. Thorne, P.E. 1991. Urban Runoff Water Quality Solutions. The American Public Works Association Research Foundation. 58 pp.

Birch, P.B. Ph.D. and H.E. Pressley (eds.) 1992. Stormwater Management Manual for the Puget Sound Basin. Review Draft. Dept. of Ecology. Publication number 90-73.

Gibb, A., B. Bennett, and A. Birkbeck. 1991. Urban Runoff Quality and Treatment: A Comprehensive Review. File number 2-51-246(242). British Columbia Research Corporation. Vancouver British Columbia.

North Carolina Department of Environment, Health, and Natural Resources, Division of Land Quality, Raleigh, NC. September 1988. Erosion and Sediment Control Planning and Design Manual.

Shueler, T.R., P.A. Kumble, and M.A. Heraty. 1992. A Current Assessment of Urban Best Management Practices: Techniques for Reducing Non-Point Source Pollution in the Coastal Zone. Publication number 92705. Metropolitan Washington Council of Governments. Washington, D.C. 127. pp.

Shueler, T. R. 1987. Controlling Urban Runoff: A Practical Manual for Planning and Designing Urban BMPs. Publication number 87703. Metropolitan Washington Council of Governments, Washington, D.C. 275 pp.

Stahre, P. and B. Urbonas. 1990. Stormwater Detention For Drainage, Water Quality and CSO Management. Prentice Hall, Inc. Englewood Cliffs. NJ. 338 pp.

U.S. EPA. 1990. Urban Targeting and BMP Selection. Information and Guidance Manual for State Nonpoint Source Program Staff Engineers and Managers. The Terrene Institute. EPA No. 68-C8-0034. 54 pp.

U.S. EPA. 1992. Stormwater Management for Industrial Activities: Developing Pollution Prevention Plans and Best Management Practices. Office of Water. Government Institutes, Inc. Rockville, MD.

Urbonas, B. and L.A. Roesner, eds. 1986. Urban Runoff Quality -- Impact and Quality Enhancement Technology. American Society of Civil Engineers. New York, NY. 477 pp.

Whipple, W., N.S. Gregg, T. Grizzard, C. W. Randall, R.P. Shubinski, and L.S. Tucker. 1983. Stormwater Management in Urbanizing Areas. Prentice Hall, Inc. Englewood Cliffs. NJ. 234 pp.

Chapter 7 Filter Strips

I. Introduction

Filter strips are sections of vegetation designed to reduce pollutants in stormwater runoff before the runoff enters a stream or other receiving water. Filter strips are carefully designed and constructed strips of relatively flat, level land with grasses or other vegetation and some method to spread the stormwater runoff into a thin sheet. If planted with grass, filter strips are sometimes called grass filter strips. Figure 18. illustrates an example of a forested filter strip with level spreader.

Another type of vegetative practice is the buffer zone or buffer strip, which is a strip of vegetation that has not been disturbed during development or has been planted along a stream or other area to be protected. Buffer zones differ from filter strips in that the land surface is not as level and there are no level spreaders or other constructed devices to spread the stormwater runoff into thin sheet flow.

Many types of plants or natural vegetation can be used in filter strips ranging from close-growing grasses to shrubs and trees. These vegetated strips work best if a level spreader is constructed along the top edge of the filter strip. One type of level spreader is a stone-filled shallow trench with the top edge of its lower bank exactly level. The crushed stone in the level spreader slows the stormwater and the level lower side makes it flow out in a thin sheet onto the filter strip. A concrete berm may also be used as a level spreader.

These devices are used between upstream development and streams or ponds, primarily in residential areas or where the development density is low. Additionally, North Carolina rules require a filter strip to be used to further treat the stormwater discharged from wet detention ponds. Because of their limited pollutant removal ability, filters are not a sufficient means by themselves to reach the 85% TSS removal requirement, but they can be used as one of a series of BMPs that, when combined, will provide sufficient protection to surface waters.

Pollutant Removal Capability. Properly constructed forested and grassed filter strips can be expected to remove a minimum of 35 percent of the solids and 40 percent of the nutrients in urban runoff. There is some indication that forested strips, or strips that use trees, appear to be more effective than grass strips because of their greater uptake and longer-term retention of plant nutrients such as nitrogen and phosphorus. However, the designer should remember that significant flow channelization in the strip can drastically reduce a strip's pollutant removal and that filter strips exhibit highly varying effectiveness from site to site.

Filter strips remove pollutants from runoff by the filtering action of the vegetation, infiltration of pollutant-carrying water and sediment deposition. The removal rate depends on many factors, including runoff velocity and degree of channelization, soil permeability, vegetation type, flow length and slope of the strip.

Improper design, location or maintenance of filter strips can lead to early failure. The formation of channels or gullies or a too-sparse vegetative cover can drastically reduce the pollutant removal of a filter. Filter strips require regular maintenance to ensure that the incoming stormwater flow is spread thinly over the entire filter strip and that the vegetation remains dense and vigorous.

Figure 18. Forested Filter Strip, From Stormwater Management Guidance Manual, NC, 1993

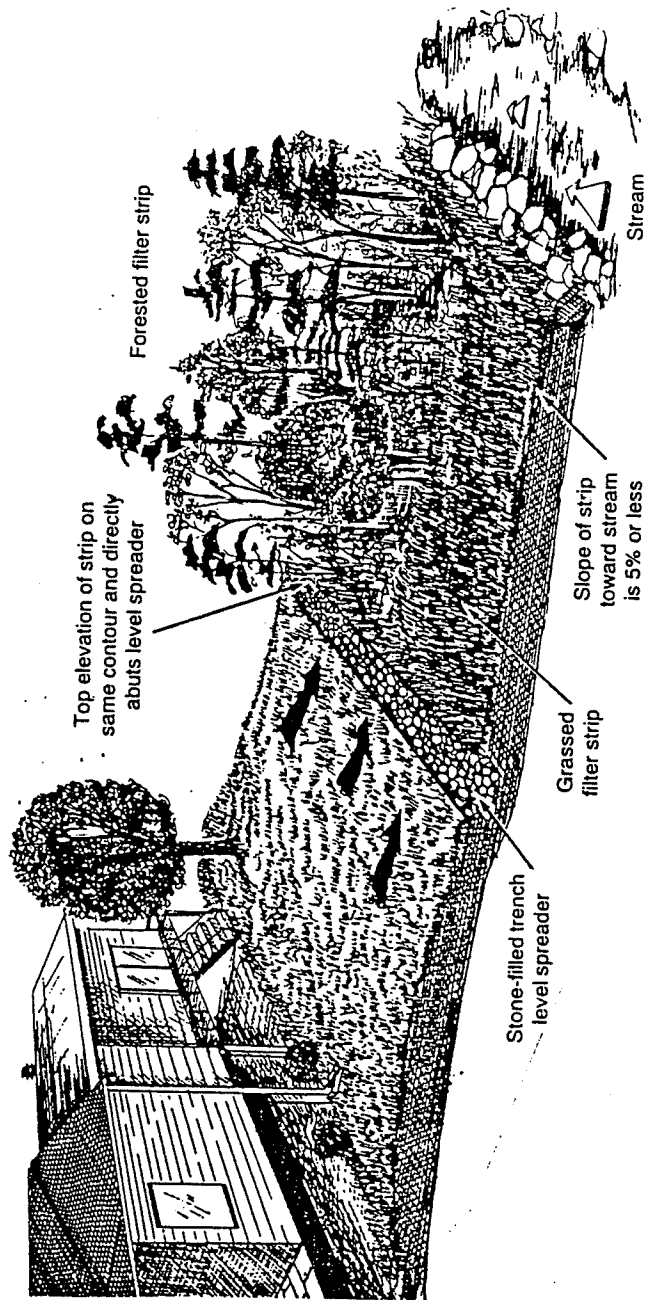

II. Advantages

Filter strips can be effective at reducing particulate pollutants such as sediment, organic matter and many trace metals. Filter strips mesh well in residential areas where they provide open space for recreational activities, help maintain the riparian zones along streams, reduce streambank erosion and provide animal habitat.

III. Disadvantages

Since filter strips are not designed to handle high velocity flows, they should generally only be used in areas with less intense development. Also, because filter strips do not provide enough runoff storage or infiltration to significantly reduce peak discharges or the volume of storm runoff, they should be viewed as only one component in a stormwater management system.

IV. Costs

The cost of establishing filter strips is usually low, requiring only minor grading and the expense of establishing vegetation. Routine maintenance activities such as inspection, sediment removal, reseeding, and removing debris are also inexpensive; however, if the strip accumulates a large volume of sediment or if concentrated flow erodes a channel through the strip, reconstruction costs may be substantial.

V. Physical Requirements

To prevent concentrated flows from forming, the drainage area contributing to the filter strip should be less than five acres and could be less, depending on watershed slope, rainfall intensities, and degree of imperviousness. Filter strips should not be used on slopes greater than 15% or in areas where vegetation cannot be maintained all year. Best performance occurs where the slope is 5% or less. Because they cannot handle high peak runoff rates, they are not suitable in relatively impervious areas such as downslope of large buildings and parking lots.

Filter strips are most effective when they are level in the direction stormwater flows over the strip, which is toward the stream. This shape encourages the stormwater to flow in a thin sheet over the strip and through the vegetation, which is best for infiltration of water into the soil and filtering of sediment and other solid particles. Deep flows or concentration of flow into channels reduces the effectiveness of the strip.

VI. Design Requirements

- Filter strips must be 50 feet in length along the direction of flow for filter strips up to 5% slope.
- Filter strips must be 50 feet plus 4 feet for every 1% increase in slope up to a maximum of 15%.
- Width of filter perpendicular to flow must be 100 feet for each acre of drainage area.
- Velocity of flow must be under 2 fps for the maximum flow resulting from a 10 year storm.
- Design must include a device such as a level spreader to allow runoff to enter the filter strip as sheet flow.
- Maximum drainage areas flowing to individual filters shall be less than or equal to 5 acres.
- If the filter strip will be used during construction, the area must be stabilized within 14 days.

- A grading and vegetation plan must be prepared by a licensed professional.

The following pollutant removal credit will be given for filter strips that meet the previously described design criteria:

40% TSS removal - for filter strips that are primarily natural, woody vegetation

30% TSS removal - for filter strips that are planted with primarily woody vegetation

25% TSS removal - for filter strips that are planted in grass or legumes

VII. Vegetation

The vegetation plan is an important aspect of the design of filter strips and will help to determine the actual amount of pollutants removed. As has been mentioned before, a natural forested area provides the best long-term removal of pollutants, and priority should be given to preventing the unnecessary removal of trees. This is especially true when the area can be demonstrated to nonerosively receive the runoff from the developed areas. If a constructed area must serve as filter strip, then the guidelines established in the Erosion and Sediment Control Planning and Design Manual, Chapters 3, 6.11-6.14, and 8.02 must be followed.

VIII. Maintenance

Most filter strips fail in a short period of time because of poor design or poor maintenance (Schueler, et al. 1992). With minimal maintenance filter strips can be effective indefinitely; however, strips that are not maintained properly may quickly become nonfunctional. Filter strip maintenance basically involves normal grass or shrub-growing activities such as mowing, trimming, or replanting when necessary. Strips that are used for sediment removal may require periodic regrading and reseeding of their upslope edge because deposited sediment can kill grass and change the elevation of the edge such that the stormwater no longer flows through the strip in thin sheets. Maintenance requirements are as follows:

- At least once annually, remove deposited sediment, especially from the upstream edge, to maintain original contours and grading,
- Repair channels that form and regrade the filter strip to ensure that the runoff flows evenly in a thin sheet over the filter strip,
- Repair level spreader whose disrepair can cause the formation of channels in the filter strip,
- Reseed and regrade the filter strip to maintain a dense growth of vegetation, especially if the strip has been used for sediment control (Schueler, et al. 1992).
- Grassed filter strips shall be mowed at least twice annually to a minimum height of six inches.

Filter strips should perform well in all areas of North Carolina where a dense, vegetative growth can be established. High-dune areas in the coastal counties are too dry to establish dense vegetation and should be avoided when locating filter strips.

IX. Peak Flow Reduction

Filter strips have limited ability to reduce peak stormwater flows. Their best use is to reduce pollutants in combination with other stormwater control practices such as dry detention basins, wet detention ponds,

infiltration devices and wetlands. They will tend to lengthen the time of concentration for most storms, and this should be taken in account when the design must also meet local peak flow requirements.

X. References

Arnold, J.A., ed. D.E. Line, S.W. Coffey, and J. Spooner. 1993. Stormwater Management Guidance Manual. North Carolina Cooperative Extension Service and North Carolina Division of Environmental Management. Raleigh, NC.

Berman, Laurel, C. Hartline, N. Ryan, and J.D. Thorne, P.E. 1991. Urban Runoff: Water Quality Solutions. The American Public Works Association Research Foundation. 58 pp.

Birch, P.B., Ph.D. and H.E. Pressley (eds.) 1992. Stormwater Management Manual for the Puget Sound Basin. Review Draft. Dept. of Ecology. Publication number 90-73.

Gibb, A., B. Bennett, and A. Birkbeck. 1991. Urban Runoff Quality and Treatment: A Comprehensive Review. File number 2-51-246(242). British Columbia Research Corporation. Vancouver, British Columbia.

North Carolina Department of Environment, Health, and Natural Resources, Division of Land Quality, Raleigh, NC. September 1988. Erosion and Sediment Control Planning and Design Manual.

Schueler, T.R., P. A. Kumble, and M. A. Heraty. 1992. A Current Assessment of Urban Best Management Practices: Techniques for Reducing Non-Point Source Pollution in the Coastal Zone. Publication number 92705. Metropolitan Washington Council of Governments. Washington, DC. 127 pp.

Schueler, T.R. 1987. Controlling Urban Runoff: A Practical Manual for Planning and Designing Urban BMPs. Publication number 87703. Metropolitan Washington Council of Governments. Washington, DC. 275 pp.

Stahre, P. and B. Urbonas. 1990. Stormwater Detention For Drainage, Water Quality, and CSO Management. Prentice Hall, Inc. Englewood Cliffs, NJ. 338 pp.

U.S. EPA. 1990. Urban Targeting and BMP Selection. Information and Guidance Manual for State Nonpoint Source Program Staff Engineers and Managers. The Terrene Institute. EPA No. 68-C8-0034. 54 pp.

U.S. EPA. 1992. Stormwater Management for Industrial Activities: Developing Pollution Prevention Plans and Best Management Practices. Office of Water. Government Institutes, Inc. Rockville, MD.

Urbonas, B. and L.A. Roesner, eds. 1986. Urban Runoff Quality--Impact and Quality Enhancement Technology. American Society of Civil Engineers. New York, NY. 477 pp.

Whipple, W., N.S. Grigg, T. Grizzard, C. W. Randall, R. P. Shubinski, and L. S. Tucker. 1983. Stormwater Management in Urbanizing Areas. Prentice Hall, Inc. Englewood Cliffs, NJ. 234 pp.

Chapter 8 Infiltration Devices

I. Introduction

Infiltration refers to the process of stormwater entering the soil. A number of infiltration devices with differing designs have been used in various locations throughout the country. This chapter discusses only three devices: infiltration basins, infiltration trenches, and dry wells.

Infiltration basins are normally dry basins, much like dry detention basins, with the exception that the stormwater does not flow out into a receiving stream. Rather, the stormwater is allowed to exfiltrate, or exit the basin by infiltrating into the soil. Obviously, infiltration basins can be used only where the soils are permeable enough to empty the basins within a reasonable time interval. Figure 19. shows an example of a traditional infiltration basin.

Infiltration trenches are ditches that fill with stormwater runoff and allow the water to exfiltrate into the soil. Some versions of infiltration trenches are filled with large crushed stone to create storage for the stormwater in the voids between the stones. Other versions use precast concrete chambers to provide a large storage volume to hold stormwater for exfiltration into the soil. Infiltration trenches are usually used to handle the water from parking lots and buildings.

Dry wells are constructed similarly to infiltration trenches but are usually more compact and not elongated. Dry wells are most useful for receiving the runoff from roofs of buildings and allowing it to exfiltrate into the soil. Dry wells that receive runoff from either roofs or completely impervious areas show the most promise for long-term water quality benefit.

North Carolina rules permit the use of infiltration practices in the coastal counties and as an alternative practice in other areas to satisfy the requirement for 85% TSS removal. Infiltration devices must meet the design requirements discussed here, of which the geotechnical investigations are an important part. [See 15A NCAC 2H.1008 for details.]

Infiltration devices are thought to have high removal efficiencies of sediment and pollutants that are adsorbed to sediment particles. Biological degradation in the soil should help reduce dissolved pollutants, depending on soil type. Data is available on actual removal capability for most dissolved pollutants.

At present, many infiltration devices seem to fail rather quickly. It appears that the soil becomes clogged with sediment, preventing infiltration. Newer designs are incorporating enhancements to remove more sediment before the sediment enters the infiltration device. Regular maintenance and proper siting will extend the life of an infiltration device.

II. Advantages

Infiltration devices put more stormwater into the soil, which more closely mimics the natural hydrology of the area. Increasing the amount of water entering the soil reduces the frequency of flooding and helps to maintain the shallow ground water that will support dry weather flows in streams. In general, pollutant removal should be as good as the best stormwater control practices.

Figure 19. Infiltration Basin with Settling Chamber. From Stormwater Management Guidance Manual, NC, 1993, Adapted from Schueler, 1987.

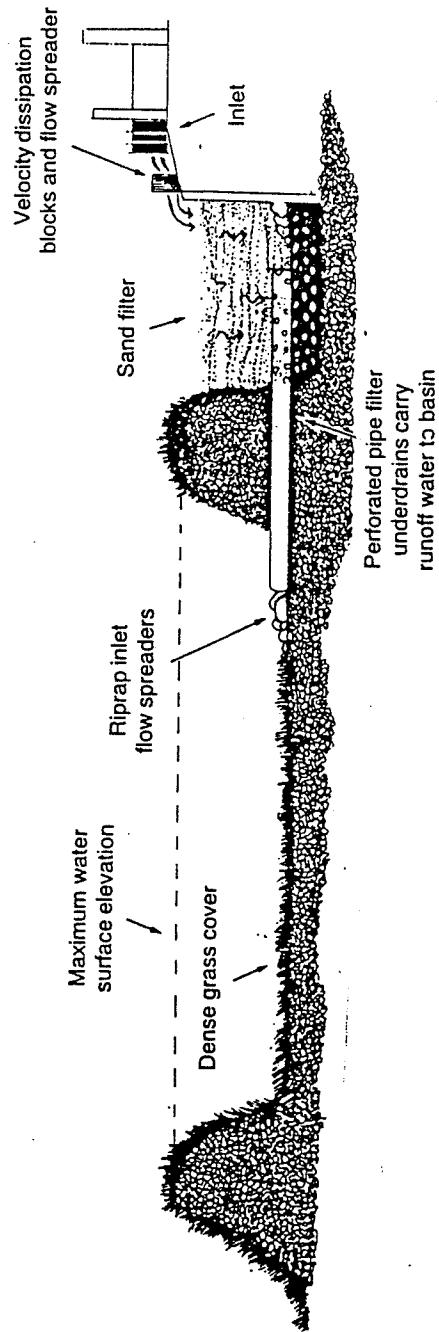

III. Disadvantages

A problem associated with the past high failure rate is that when a BMP fails, the stormwater receives little treatment. Also, devices which use infiltration are restricted to those areas with permeable soils, deep water tables, deep bedrock and stable areas where the stormwater contains little sediment. The greatest potential concern about infiltration practices is that infiltration of stormwater may contaminate ground water. To date, no major contamination has occurred (Schueler, et al. 1992).

IV. Costs

Infiltration devices are less expensive than large wetlands, but more expensive than a simple dry detention basin. Given that infiltration devices can often fit into areas with limited space, they may be the most cost-effective control available in some situations. Also, there are situations where an infiltration device may be constructed beneath an impervious surface, thereby consuming no developable land.

V. Design Requirements

- Soils must have been tested and shown to infiltrate a minimum of 0.52 inches/hour at the bottom of the device.
- Infiltration devices must capture and infiltrate the runoff from first 1.5 inches of rainfall for areas that drain to SA classified waters, and 1.0 inches of rainfall in all other areas.
- Drawdown of this runoff must occur within 5 days.
- The maximum drainage area that should flow to a single device is 5 acres.
- Pretreatment devices such as catch basins, grease traps, filter strips, grassed swales and sediment traps must be used to protect infiltration devices from clogging.
- All infiltration devices should be sited a minimum of 30 feet from surface water, 50 feet from Class SA waters, and 100 feet from any water supply wells.
- The bottom of the infiltration device should be a minimum of 2 feet above the seasonal high water table, with greater separation desirable.
- The bottom of the infiltration device must be a minimum of 3 feet above any bedrock or impervious soil horizon.
- The bottom of the device must be lined with a layer of clean sand with an average depth of four inches.
- The sides of an infiltration trench must be lined with geotextile filter fabric.
- The rock used in infiltration trenches must be free of fines (washed stone) and have as large a void ratio as possible. Rounded stone, such as beach gravel, has a larger void ratio than angular crushed stone.
- Infiltration devices must be designed as off-line BMPs. This means that runoff in excess of the design volume by-passes the system.
- Infiltration devices should not be constructed on fill material, but would be allowed on a case-by-case basis.
- At least one observation well should be included in the design of an infiltration device and may be required on a case-by-case basis.
- Runoff should not be directed to an infiltration device until the drainage area is stabilized

Other Design Guidelines:

- Infiltration devices work best for smaller drainage areas and drainage areas that are completely stable or impervious.
- Thick vegetation on the bottom of infiltration basin should be maintained.
- Infiltration trenches should be wide and shallow rather than deep and narrow. The ratio of side-to-bottom area should be less than 4:1. The sides and bottom should be lined with filter fabric (geotextile fabric) to prevent clogging.
- Infiltration devices should be located away from foundations of buildings and other sensitive structures.

Failure rates for infiltration devices appear to be high. Schueler cites studies which indicate that only about half of the infiltration trenches and even fewer infiltration basins functioned as long as five years (Schueler, et al. 1992). Many of these devices failed due to clogging and lack of maintenance.

VI. Peak Flow Reduction

Infiltration devices are used to improve the quality of the stormwater and are not primarily directed to reducing peak flows or stormwater volume, especially from larger storms that are bypassed around the system. However, because they prevent some water from running off, they will reduce the peak flows.

VII. Maintenance

While there should be little routine maintenance needed for most infiltration devices, the maintenance that is required is very important, and property owners must be educated in the function and maintenance requirements of the infiltration device. Especially important is the maintenance of vegetated areas that drain to the infiltration system. Areas that are allowed to become bare and unvegetated will contribute excess sediment to the infiltration system and hasten its failure.

Maintenance Requirements:

- Annual inspections must be conducted after a storm event to ensure infiltration performance.
- Grass filters leading to infiltration basins should be mowed at least twice a year.
- Sediment deposits should be removed from pretreatment devices at least annually.
- Removal and reconstruction of the infiltration device will be necessary when the infiltration rate drops to unacceptable levels.

VIII. References

Arnold, J.A., ed. D.E. Line, S.W. Coffey, and J. Spooner. 1993. Stormwater Management Guidance Manual. North Carolina Cooperative Extension Service and North Carolina Division of Environmental Management. Raleigh, NC

Berman, Laurel, C. Hartline, N. Ryan, and J.D. Thorne, P.E. 1991. Urban Runoff: Water Quality Solutions. The American Public Works Association Research Foundation. 58 pp.

Birch, P.B., Ph.D. and H.E. Pressley (eds.) 1992. Stormwater Management Manual for the Puget Sound Basin. Review Draft. Dept. of Ecology. Publication number 90-73.

Gibb, A., B. Bennett, and A. Birkbeck. 1991. Urban Runoff Quality and Treatment: A Comprehensive Review. File number 2-51-246(242). British Columbia Research Corporation. Vancouver, British Columbia.

North Carolina Department of Environment, Health, and Natural Resources, Division of Land Quality, Raleigh, NC. September 1988. Erosion and Sediment Control Planning and Design Manual.

Schueler, T.R., P. A. Kumble, and M. A. Heraty. 1992. A Current Assessment of Urban Best Management Practices: Techniques for Reducing Non-Point Source Pollution in the Coastal Zone. Publication number 92705. Metropolitan Washington Council of Governments. Washington, DC. 127 pp.

Schueler, T.R. 1987. Controlling Urban Runoff: A Practical Manual for Planning and Designing Urban BMPs. Publication number 87703. Metropolitan Washington Council of Governments. Washington, DC. 275 pp.

Stahre, P. and B. Urbonas. 1990. Stormwater Detention For Drainage, Water Quality, and CSO Management. Prentice Hall, Inc. Englewood Cliffs, NJ. 338 pp.

U.S. EPA. 1990. Urban Targeting and BMP Selection. Information and Guidance Manual for State Nonpoint Source Program Staff Engineers and Managers. The Terrene Institute. EPA No. 68-C8-0034. 54 pp.

U.S. EPA. 1992. Stormwater Management for Industrial Activities: Developing Pollution Prevention Plans and Best Management Practices. Office of Water. Government Institutes, Inc. Rockville, MD.

Urbonas, B. and L.A. Roesner, eds. 1986. Urban Runoff Quality--Impact and Quality Enhancement Technology. American Society of Civil Engineers. New York, NY. 477 pp.

Whipple, W., N.S. Grigg, T. Grizzard, C. W. Randall, R. P. Shubinski, and L. S. Tucker. 1983. Stormwater Management in Urbanizing Areas. Prentice Hall, Inc. Englewood Cliffs, NJ. 234 pp.